



# **STANDARDS FOR DEVELOPMENT AND CONSTRUCTION**

**2021**



# Forward

It is the goal and objective of the Township of Spring Lake to provide high quality and cost effective infrastructure as well as thoughtful, responsible development for its current and future citizens. To accomplish this, it is necessary to assure quality development through uniform performance standards for the design and construction of the Township's infrastructure. To implement this objective, it is important that certain guidelines be adopted in order to standardize engineering requirements within the Township.

These standards outline certain requirements, materials, and practices that will be incorporated into development plans and specifications for site layout, storm sewer, street construction, and grading within the Township of Spring Lake.

This manual is NOT a specification in itself. All Construction and Development projects within the Township will require a complete and competent set of specifications for the work.

This manual is intended as a reference source of information, standards, and data. Particular sections or information in this manual may be incorporated into project specifications by reference as deemed appropriate by the Township Engineer, provided this manual is made available to those to whom the reference is intended. Projects must comply with the requirements outlined in this manual, unless otherwise allowed by the Town Board.

From time to time this manual will be amended by official action of the Township Board. The most recent update of this manual shall dictate the requirements for a project at the time of the plan approval.

Mark R. Statz, P.E.  
Township Engineer, Reg. No. 42717

This Page Left Blank Intentionally

Table of Contents

Forward .....1  
Land Use Guidelines.....5  
Engineering Design Standards ..... 10  
Standard Specifications and Detail Plates ..... 45

Timeline

Standards for Development and Construction ..... Adopted June 2010  
Revisions to Standards ..... Adopted Oct. 2010  
Revisions to Land Use Guidelines ..... Adopted May 2014  
Updates to Detail Plates ..... June 2017





## **LAND USE GUIDELINES**

**2014**





Spring Lake Township has adopted these standards and specifications to guide development within the area designated in the Scott County Comprehensive Plan as the Rural Residential Service Area (RRSA). These Township standards and specifications, which may be more restrictive than comparable conditions imposed by County regulations, are anticipated and accommodated in the Scott County Zoning Ordinance in Chapter 1 1-3 Application 3 Standard, Requirement, and the Scott County Land Subdivision Ordinance Chapter 10 Improvements 10-2 Standards and Requirements.

#### **A. The appropriate intensity of development in the Rural Residential Service Area**

Incorporating the Town's standards and specifications for the design of development in the RRSA in combination with the conditions found at each site may result in the reduction of the theoretical maximum intensity of development at the site from the maximum intensity quantitatively allowed by the County's standards. The Town Board in adopting these standards and specifications recognizes these qualitative improvements may reduce the quantitative efficiency of the proposed development. Along with the opportunity for more intense development in the Township provided by the RRSA strategy, the Board strongly supports and values implementing these qualitative standards. The appropriate intensity of development at each unique site will be that provided by the plan for development of that site implementing these planning design standards and specifications.

#### **B. The desired character of development in the Rural Residential Service Area (RRSA)**

The goal of the Township for development using the unique opportunity provided by the RRSA designation is development that connects home sites with nature while disconnecting them from their neighbors. The Town promotes these values during the process of development:

- A. Identifying and respecting the natural features of the site for incorporation into the character of each development and to shape its design.
- B. Encouraging development that connects to natural areas but responsibly disconnects and sustains each parcel as an independent unit for utilities, by disconnection of each home's on-site septic treatment from others in the development (no community systems)
- C. Anticipate and respect the continuation of agricultural activities on adjacent larger parcels (10 or more acres) in the design of the development.

#### **C. The standards and specifications of Spring Lake Township for approval of residential developments within the Rural Residential Service Area.**

### **2. Minimum Lot Width – Development of 12 Acres or Less**

For new development of 12 acres or less the minimum lot width must be 200 ft measured at the front setback line as provided in Section 1-7 Definitions "Lot Width" in the Scott County Zoning Ordinance. Where a strict conformance to this rule is not practicable, the board may allow lots as narrow as 150 feet with the following conditions: 1) Lots less than 200 feet in

width are not adjacent to each other, and 2) the average width of lots in the subdivision is greater than 200 feet.

**D. The adjustment of these standards and specifications**

The Town Board may authorize adjustments of these standards and specifications upon finding:

1. The requested specific adjustment is warranted due to specific conditions at the site
2. The requested specific adjustment will contribute to meeting the goals and objectives for development in the RRSA at this site.

If a pipe and pond system for stormwater management is permitted by an adjustment, the area served by the system must be minimized, affecting the least possible area of the site.

This Page Left Blank Intentionally



# **ENGINEERING DESIGN STANDARDS**

**2010**



# Table of Contents

Table of Contents.....	12
Definition of Terms .....	14
Statement of Policy .....	16
Public Infrastructure Installation .....	16
General Engineering Requirements.....	20
Design Standards.....	24
Storm Sewer.....	24
Grading/Erosion Control .....	27
Streets/Trails .....	29
Construction Plan Standards .....	33
General Requirements.....	33
Specific Requirements .....	33
Record Plan Requirements.....	35
Construction Requirements.....	37
Subdivision Monumentation .....	37
Suggested Construction Staking Guidelines.....	37
Inspection .....	37
Testing Requirements .....	37
Installation Requirements.....	38
Final Project Completion/Acknowledgment.....	41
Building Requirements.....	42
Miscellaneous .....	44

This Page Left Blank Intentionally

# Definition of Terms

Approved Plat:	Shall mean a final plat that has been accepted by the Township Board and is recorded at the Scott County Court House.
Benchmark:	Shall mean a permanent or semi-permanent physical mark of known elevation. The elevation shall be tied to the U.S.G.S. Sea Level Datum.
Builder:	Shall mean the person applying for and receiving a building permit to perform the work requested in said permit.
Building Official:	Shall mean the duly appointed Building Official of the Local Permit Authority or his/her designated representative.
Contract Documents:	Shall mean, unless the context provides otherwise, either a Development Contract entered into between the Township and the Developer, or any Agreement existing between two or more persons, whether written or oral, setting forth the obligations of each party.
Contractor:	Shall mean, depending on the context, a person under contract with the Township to perform labor or work for the Township; or a person under contract with a Developer to install municipal.
Construction:	Is the total process of furnishing labor, material and equipment to arrange and combine the parts into a completed project in accordance with the approved plans and specifications.
Developer:	Shall mean the person who has executed, or proposes to, execute a developers agreement with the Township of Spring Lake and/or the County for the purpose of subdividing land within the Township; and shall, where appropriate, include Developer, Developer's Engineer, Contractor Agents or Employees either individually or collectively.
Freeze-Thaw Cycle	Freeze-thaw cycle shall mean one winter season, typically from November 1 <sup>st</sup> through April 30 <sup>th</sup> .
Person:	Shall mean an individual, corporation, partnership, or any combination thereof.
Plans:	The approved drawings which include plan views, profiles, cross sections, working drawings, details, and supplemental drawings, or exact reproductions thereof, which show the location, character, dimensions, extent, limits and all else necessary to complete the work covered by the project.
Record Plans:	Shall mean the corrected or adjusted construction plans that accurately show the distances, elevations, dimensions, details, and all other changes to reflect the actually completed work as constructed.
Site Inspection:	Observance of infrastructure construction to monitor compliance with the approved construction plans and Township standards.



Specifications:	The body of written directives, provisions, and requirements made pertaining to the methods or manner of performing the work, the quantities, and the quality of materials to be furnished under the contract; and outlining the obligations and responsibilities of the parties to the contract; and setting forth the method of payment and the duration of the work.
Standard Plates:	Shall mean those detail drawings or plates prepared for and approved by the Township of Spring Lake.
Township:	Shall mean the Township of Spring Lake, Scott County, Minnesota.
Township Board, Town Board, or Board:	Shall mean the Township Board of the Township of Spring Lake.
Township Clerk:	Shall mean the duly appointed Township Clerk of Township of Spring Lake or his/her designated representatives.
Township Engineer:	Shall mean the duly appointed Township Engineer of the Township of Spring Lake or his/her designated representatives.
Township Inspector:	Shall mean duly appointed Township Inspector or Project Engineering Inspector of the Township of Spring Lake or their designated representatives.
Township Planner:	Shall mean the duly appointed Township Planner of Township of Spring Lake or his/her designated representatives.
Warranty Period:	That period of time commencing from written acceptance by the Township Board of public improvements that the developer warrants those improvements free from defect.

# Statement of Policy

## **PUBLIC INFRASTRUCTURE INSTALLATION**

### **PURPOSE:**

The purpose of this policy is to establish the Township's policies and procedures for the construction of public streets and utilities in new developments.

It is the Township's responsibility to provide and ensure the public health, safety, and welfare through the Township's infrastructure including the storm water drainage system, transportation systems, and related appurtenances. Once constructed, these facilities are owned, operated, maintained, and ultimately reconstructed by the Township, which requires substantial investment of taxpayer dollars. Due to these financial obligations it is important for the Township to clarify the Township's policy towards constructing new public improvements in developments.

### **STATEMENT OF POLICY:**

This policy, as adopted by the Township Board and placed into practice by the Township of Spring Lake, establishes the basis for the design and construction of development in the Township for the following reasons:

1. To ensure consistency and compatibility with the Township's existing infrastructure systems.
2. To ensure maximum control by the Township of system components that will ultimately be owned and maintained by the Township.
3. To ensure construction meets Township Standards.
4. To avoid potential insurance liability problems.
5. To ensure completion of a facility once construction is initiated.
6. To ensure record plans (as-builts) are properly prepared and filed.
7. To minimize the amount of staff time and consequent taxpayer dollars that are being spent in educating numerous privately employed design personnel about Township ordinances, standards, and procedures.
8. To ensure public health safety and welfare

The following describes four options for the delivery of a development and the related public infrastructure. Other options could be considered by staff and the Board based on a request from the Developer. The Township reserves the right to choose or deny the use of any option in the best interest of the Township at its sole discretion.

### **PUBLIC INFRASTRUCTURE DELIVERY POLICY:**

#### **OPTION 1 – DEVELOPER DESIGN, CONTRACT AND FINANCING; TOWNSHIP REVIEW AND OBSERVATION:**

The Developer:

- Designs the plat and grading plan
- Designs the public improvements plan
- Contracts for the grading and other private improvements
- Contracts for the public improvements

- Provides construction staking
- Pays the contractor(s)
- Submits a letter of credit for 125% of the project costs (both construction and soft costs)
- Reimburses the Township for its costs to complete the items listed below and any other development related costs

The Township:

- Reviews the plat and grading plan
- Reviews the public improvements plan
- Performs full time construction observation
- Performs materials testing

The letter of credit may be periodically reduced as work is completed and accepted.

OPTION 2 – TOWNSHIP DESIGN AND OBSERVATION; DEVELOPER CONTRACT AND FINANCING:

The Developer:

- Designs the plat and grading plan
- Contracts for the grading and other private improvements
- Contracts for the public improvements
- Pays the contractor(s)
- Submits a letter of credit for 125% of the project costs (both construction and soft costs)
- Reimburses the Township for its costs to complete the items listed below and any other development related costs

The Township:

- Reviews the plat and grading plan
- Designs the public improvements plan
- Approves the developer’s contractor for the public improvements
- Performs full time construction observation and staking
- Performs materials testing

The letter of credit may be periodically reduced as work is completed and accepted.

OPTION 3 – TOWNSHIP DESIGN, CONTRACT, AND OBSERVATION; DEVELOPER FINANCING:

The Developer:

- Designs the plat and grading plan
- Contracts for the grading and other private improvements
- Pays the contractor for the grading and other private improvements
- Establishes a “Construction Account” in the amount 125% of the project costs (both construction and soft costs) to be drawn upon by the Township in order to pay its contractor
- Reimburses the Township for its costs to complete the items listed below and any other development related costs

The Township:

- Reviews the plat and grading plan
- Designs the public improvements plan
- Contracts for the public improvements
- Pays the public improvements contractor out of the "Construction Account"
- Performs full time construction observation and staking
- Performs materials testing

OPTION 4 - TOWNSHIP DESIGN, CONTRACT, OBSERVATION, AND FINANCING:

The Developer:

- Designs the plat and grading plan
- Contracts for the grading and other private improvements
- Pays the contractor for the grading and other private improvements
- Requests that the township construct the public improvements and assess the costs of such improvements to the development property under Chapter 429.
- Waives all appeal and hearing rights under Chapter 429.
- Reimburses the Township for its costs to complete the items listed below and any other development related costs

The Township:

- Reviews the plat and grading plan
- Designs the public improvements plan
- Contracts for the public improvements
- Assesses the development property(ies) for the full cost of the public improvements including construction and soft costs not previously reimbursed by the developer.
- Performs full time construction observation and staking
- Performs materials testing

This Page Left Blank Intentionally

# General Engineering Requirements

Developers of property within the Township of Spring Lake are required to submit certain plans and specifications for review and approval by the Township. These include such items as existing conditions/site survey/ grading plans, plats, street plans, utility plans, erosion control plan, landscaping plan, signage plan, and lighting plans. If the project is not designed by the Township Engineering staff, the Developer must also submit construction plans, project specifications, and as-built construction plans. A competent professional engineer that is licensed to practice in the State of Minnesota shall prepare these plans and specifications.

The professional services required of the Developer might include an Architect, Land Surveyor, Planner, and Engineer. The engineering services include not only preparation of plans and specifications but field staking and site inspection in order to assure the Township of a quality product and to assure that the completed project is in conformance with the approved plans and specifications.

If the Developer installs the required public improvements within the development under Option 1, the following procedures shall be followed:

1. After Preliminary Plat approval, the Developer shall submit the following for review and approval by the Township:
  - Street & Utility Plan
  - Grading Plan
  - Landscaping Plan
  - Street Lighting Plan
  - Signage Plan
  - Plat
  - Storm Sewer Design Calculations (Hydrology map and Rational Worksheet)
  - Specifications (Grading, Streets and Utilities)
  - Soil Report with Recommendations
  - Construction cost estimates for development contract preparation
2. Collector streets are to be designed to meet or exceed the Mn/DOT standards for 40-mph.
3. All utility testing, grading as-builts, curb and gutter and bituminous base, raising of structure iron, erosion control and signage shall be completed and approved prior to issuance of building permits. However, the Township may waive this requirement when weather related circumstances prevent completion of street projects before the end of the construction season. The Developer is responsible for maintaining said streets in a condition that will assure the access of emergency vehicles at all times when such a waiver is granted. Concrete curb and gutter installation and bituminous paving will occur solely at the discretion of the Township after October 15.
4. The Developer shall submit an erosion and sediment control plan to the Township for review and approval. No work is to begin until all erosion and sediment control measures are in place.
5. Developer will provide competent engineering services for staking and site inspection for the construction of improvements, unless other arrangements are made in advance with the Township.
6. Copies of project bids, change orders, written field instruction, test reports, etc. shall be forwarded to the Township Engineer in a timely manner.

7. The Developer shall furnish the Township with a list of contractors being considered for construction of the project. The Township reserves the right to reject any contractor.
8. Any changes or modification to the plans or specifications shall be submitted to the Township and approved by the Township Engineer in writing before they are made.
9. The Township will provide construction site inspection of the work as it deems necessary. The cost of all site inspections and related items will be charged back to the Developer. The Township must be notified a minimum of 48 hours in advance of all work so a Township representative can be present if appropriate. Failure to notify the Township or to provide adequate notice may lead to rejection of the work.
10. Upon completion of all work required, the Township Engineer or a designated Township representative will make a final inspection of the completed work. Representatives of the Developer may accompany the Township's representative during the final inspection. Before final payment is made to the Contractor by the Developer, the Township Engineer shall be satisfied that all work is satisfactorily completed in accordance with the approved plans and specifications, including placement of the wear course. The Developer's Engineer shall submit a written statement to the Township Engineer attesting that to the best of his/her knowledge the work has been completed in accordance with the approved plans and specifications. Acceptance of the work shall be made by resolution of the Township Board upon the recommendation of the Township Engineer.
11. The bituminous wear course cannot be laid until the completed utilities and bituminous base course have gone through a minimum of one freeze-thaw cycle and the Township has reviewed record plans. Additional time may be required at the discretion of the Township Engineer.
12. The Developer will warrant all improvements required to be constructed by the Development Contract against poor material and faulty workmanship. The warranty period for streets and underground utilities is two years. The warranty period shall commence after the final wear course has been completed and the improvements have been accepted by Township Board resolution. All trees shall be warranted to be alive, of good quality, and disease free for twelve (12) months after the security for the trees is released upon an inspection of the landscaping to ensure all plantings are compliant with the approved landscape plan. Any replacements shall be warranted for twelve (12) months from the time of planting. The Developer shall post maintenance bonds or other surety acceptable to the Township to secure the warranties. The Township shall retain ten percent (10%) of the security posted by the Developer until the bonds or other acceptable surety are furnished to the Township or until the warranty period has been completed, whichever first occurs. The retainage may be used to pay for warranty work. NOTE: Township Board acceptance will not occur until all work order items are complete.
13. Upon completion of the base course, the Developer shall provide the Township a full set of record plans and an electronic set of all drawings as outlined in this manual. Such record plans shall be completed and submitted to the Township Engineer within three (3) months of completion of the work. The Developer or its Surveyor/Engineer shall provide to the Township a copy of the plat and as-built utility improvements on computer disc. See record plan section for requirements.

Under Options 2, 3 and 4 as outlined in the Statement of Policy, the following procedures shall be followed.

1. The Developer shall submit:
  - Preliminary plat with sufficient information to enable the Township Staff to review the proposed development and to determine that the development can be provided with utility service.
  - Conceptual Street & Utility Plan
  - Grading Plan
  - Landscaping Plan
  - Soil Report with Recommendations (if available as part of Grading Plan)
2. The Township of Spring Lake will provide a final design for the approved plat, and will prepare construction plans and specifications for the utility and street improvements. The Township of Spring Lake will administer the construction contract and provide construction staking and resident construction inspection in accordance with the provisions set forth with the designated Option.
3. The Developer will be responsible for site grading and for rough grading the street right-of-ways. The Developer will also be responsible for erosion control as outlined above.
4. The Developer will provide all on-site improvements required by the final approval of the subdivision, including such items as landscaping; street lighting; street signs; special berming; storm water holding ponds; paths and walkways; etc.
5. A copy of the Township of Spring Lake Engineering Standards with Standard Detail Plates is on file for review at the Township Hall or may be purchased in accordance with the current fee schedule.
6. Prior to beginning construction, the Developer shall obtain and submit to the Township all regulatory agency permits and approvals.
7. Developer will coordinate with all private utilities regarding the construction of new facilities and reconstruction of existing.



This Page Left Blank Intentionally

# Design Standards

This information has been prepared to assist developers and their engineers in the planning and construction of public infrastructure in the Township of Spring Lake. It is not intended to be, nor should it be used as a specification for any improvement, but rather a guideline to be used in the preparation of such documents.

## **STORM SEWER**

Drainage facilities shall conform to the requirements of Scott County and the local watershed district, and the Township's most recent Standard Detail Plates and Engineering Design Standards

The Township of Spring Lake may inspect and enforce erosion and sediment control practices on construction sites in the Township of Spring Lake.

The developer shall obtain all regulatory agency permits and approvals as required. The following are specific requirements related to the development of drainage facilities:

### General

1. Riprap and filter blanket shall be placed at all outlet flared end sections. The placement of the riprap shall be hand placed. Design criteria justifying the size and amount of riprap is required (see Standard Detail).
2. Junction manholes should be designed to limit the hydraulic head increase by matching hydraulic flow lines and by providing smooth transition angles. Intersection angles must be a minimum of 90 degrees.
3. Over-excavate the bottom of the water quality ponds to compensate for any erosion that could occur. The developer will be responsible for verifying, at the end of the warranty period, that the ponds are providing the required volumes.
4. Under Option #4, calculations and drainage area maps showing 5 year design and 100 year flood boundaries shall be submitted with the plans and specifications verifying the adequacy of the number of catch basins, pipe capacities, and pond sizes.
5. The lowest floor elevation of a structure in a development that adjoins a pond will be at a minimum of two feet above the ponds 100 year storm HWL elevation or one foot above its emergency overflow elevation whichever is less restrictive.
6. The lowest opening elevations near emergency overflow swales and ditches shall be a minimum of two feet above the 100 year storm HWL elevation of the swale or ditch.
7. Provide for emergency overflow routes to drain low points along streets or lot lines to ensure a freeboard of two feet from the lowest opening elevation and the calculated 100 year storm HWL elevation. Street ponding shall not exceed a maximum depth of 3' at its deepest point. Design criteria verifying the adequacy of the overland drainage route capacity is required.
8. Inlets will generally be required every 400' on streets or a combination of streets and swales. Additionally, inlets should be located such that 3 cfs is the maximum flow at the inlet for the 5 year flood design storm event.
9. Minimum pipe cover in paved areas shall be 2.5'. In unpaved areas, the minimum cover shall be 2.0'.

10. Storm sewer shall be designed to maintain a self-cleaning pipe velocity. The minimum full flow velocity shall be 3 feet per second (fps). The maximum velocity shall be 10 fps, except when entering a pond, where the maximum velocity shall be limited to 8 fps.
11. Any storm ponds shall be designed and constructed to meet National Urban Runoff Program (NURP) design standards.
12. Storm water detention facilities constructed in the Township of Spring Lake shall be designed according to the most current technology as reflected in the MPCA publication "Protecting Water Quality in Urban Areas," and shall contain, at a minimum, the following design factors to the extent possible:
  - An average permanent pool depth of four to ten feet.
  - A permanent pool length-to-width ratio of 3:1 or greater.
  - A ten foot wide maintenance bench shall be provided with a slope of 10' horizontal to 1' vertical (10:1) and elevated above the normal water level.
  - A protective buffer strip of vegetation surrounding the pond will be required. The minimum width of the buffer is 10', or as required by the Township Engineer.
  - Storm water detention facilities for new development must be sufficient to limit peak flows in each sub-watershed to those that existed before the development for the 100 year storm event.
13. Wetlands
  - Wetlands must not be drained or filled, wholly or partially, unless replaced by restoring or creating wetland areas in accordance with the "Minnesota Wetland Conservation Act" and other wetland regulations.
  - Utilization of existing wetlands for storm water management is subject to review by the appropriate regulatory agency in accordance with the "Minnesota Wetland Conservation Act" and other wetland regulations.
14. Easements
  - A standard 5-foot wide drainage and utility easement shall be provided along all side and rear lot lines. A 10-foot wide drainage and utility easement shall be provided along front lot lines and all right-of-way/property lines.
  - If a developer's proposal involves directing some or all runoff off of the site, it shall be the responsibility of the applicant to obtain from adjacent property owners any necessary easements or other property interests concerning flowage of water.
  - Easements are required for all ponding areas to the basin's 100 year storm HWL elevation, for all inletted and outletted basins, swales, ditches, and overflow routes to the basin's 100 year storm HWL elevation.
  - If the storm sewer is to be installed less than 10' deep within private property, the easement shall be a minimum of 20' wide with the pipe centered in the easement. If the storm sewer is 10' deep or greater, then the easement shall be twice as wide as the depth.
  - At all locations where utilities cross easements containing ponds, wetlands, ditches, or other water features, the utility shall be installed with a trace wire and access boxes. For open cut installation, the trace wire shall be Copperhead High Strength 1230-HS, or Engineer Approved Equal. For directionally drilled or bored installations, the tracer wire shall be Copperhead SoloShot-EHS, or Engineer Approved Equal. Trace wire access boxes shall be SnakePit Lite Duty, or Engineer Approved Equal. Trace wire and access boxes shall be green for sanitary service applications and blue for water service applications.
15. Show or define access routes for maintenance purposes to all manholes, inlets, and/or outlets at ponding areas that are outside of public right-of-way. Access routes shall have a 7% maximum grade, 2% cross slope, minimum horizontal curve radius of 50', a minimum width of 12', and shall not cross wetlands. Accesses shall be dedicated at the time of final platting in the form of drainage and utility easements shown on the plat.

17. With the development of any subdivision or ponding area, the developer is responsible for the removal of all significant vegetation (trees, stumps, brush, debris, etc.) from any and all areas which would be inundated by the designated controlled water elevation (Outlet Elevation) of any required pond as well as the removal of all dead trees, vegetation, etc., to the HWL of the pond.
18. The invert elevations of the pond inlet flared end sections shall be no lower than the Outlet Elevation of the pond. Submerged inlets will only be allowed at the discretion of the Township Engineer.
19. The developer and/or engineer upon the completion of the construction of a designated ponding area is required to submit a record drawing plan of the ponding area certifying the pond construction and that the pond meets all design parameters as set forth in the proposed site.
20. Erosion control shall at a minimum observe standards established in the following reports: "Protecting Water Quality in Urban Areas" (Best Management Practices for Minnesota), "National Urban Runoff Program" (NURP), and National Pollutant Discharge Elimination System / State Disposal System (NPDES/SDS) General Stormwater Permit or as modified herein.
21. No overland or channeled storm water may leave a development site in excess of the existing rate. The storm water in each phase of a development will need to be managed to this criteria and any interim storm water design for the development will need to meet this criteria.
22. All newly constructed and reconstructed buildings will route drain leaders to pervious areas wherein the runoff can be allowed to infiltrate. The flow rate of water exiting the leaders shall be controlled so no erosion occurs in the pervious areas.
23. Manholes shall be placed in paved surfaces wherever possible.
24. If differing pipe sizes exist at manhole junctions, the pipe crowns should be at the same elevation
25. Catch basins shall be located on the tangent section of the curb at a point 5' from the return. Mid-radius catch basins will not be allowed. Also, catch basins shall be designed to collect drainage on the upstream side of the intersection.
26. Minimum storm sewer pipe size shall be 12 inches diameter. Minimum draintile pipe size shall be 4 inches diameter.
27. The maximum spacing between manholes is 400' for storm sewer lines less than 24" in diameter and 500' for storm sewer lines 24" to 30" in diameter. Maximum spacing on large diameter storm sewer lines shall be approved by the Township Engineer.
28. When approved by the Township, the last manhole in a paved area before entering a ponding area may have a sumped bottom unless otherwise approved by the Township Engineer. The sump shall be a minimum of 2.0' in depth.
29. Any connections to existing manholes or catch basins shall be core drilled or the opening cut out with a concrete saw. No jack hammering or breaking the structure with a maul is permitted. Also, all connections to an existing system will require a manhole for access.
30. Aprons or flared end sections shall be placed at all locations where the storm sewer outlets to a ponding area. All aprons or flared end sections shall be tied to the next three (3) pipes. All trash guard installations will be subject to approval by the Township Engineer. The Township standard for aprons or flared end sections is the most current version of Standard Detail for Concrete Apron for Reinforced Concrete Pipe.
31. Connection of private drain lines to the public storm sewer system is regulated by the Township's policy on this matter. The township clerk may be contacted for a copy of this policy. Unless otherwise stated in the policy, the connection shall comply with the requirements for municipal storm sewer as described herein and the International Building Code (IBC).

## **PRODUCTS**

1. Manholes frames and covers shall be of the best grade of cast iron, free from all injurious defects and flaws and shall be Class 35 iron in accordance with ASTM Spec A-48. Each casting shall be sand blasted but no further coating or finish is required. Both the surface of the frame and the cover shall have machine bearing surfaces with two concealed pick holes. The words "Storm Sewer" shall be stamped on the cover in two-inch letters.
2. Reinforced concrete pipe (RCP) shall conform to the requirements of the Standard Specifications for Reinforced Concrete Sewer Pipe, ASTM Designation C-76 of the class designated on the plans and in the specifications. Pipe joints shall meet the requirements of ASTM Specification C-361 and shall be the Bureau of Reclamation Type R-4.
3. Polyvinyl chloride (PVC) pipe, where allowed, shall be in accordance with ASTM specification D-3034. Pipe shall be produced by a continuous extrusion process using Type I, Grade 1 material as defined in ASTM Specification D-1784. Prior written approval from the Township Engineer is required for the use of PVC. PVC storm sewer will generally be limited to areas of extremely low surface cover, or for use in drain tile applications.
4. Corrugated metal pipe (CMP), where allowed, shall be in accordance with Mn/DOT Section 3236, Type I, 16-gauge material. Prior written approval from the Township Engineer is required for use of CMP. CMP storm sewer will generally be limited to culverts, areas of extremely steep grade, soft and unusual trench conditions, etc.
5. Foundation material for storm sewer - See Bedding Detail Plates.
6. Flared end sections shall be reinforced concrete pipe in accordance with Standard Detail.
7. The minimum class of riprap shall be Mn/DOT 3601.2 Class III.
8. Refer to the Standard Detail Plates for the types of castings to be used on the storm sewer structures.
9. All storm sewer inlets, outlets and manholes that are not within a paved area will be marked per the Standard Detail Plates.
10. Outlet control structures from ponding areas are required as shown on the Standard Detail Plates.

## **GRADING/EROSION CONTROL**

The grading plans and erosion control systems shall conform to the most recent editions of "Protecting Water Quality in Urban Areas" (Best Management Practices for Minnesota), "National Urban Runoff Program" (NURP), National Pollutant Discharge Elimination System / State Disposal System (NPDES/SDS) General Stormwater Permit or as modified herein and the Township's most recent Standard Detail Plates and comprehensive plans. These comprehensive plans contain information that the design professional must incorporate in the design of a public infrastructure within the Township.

The developer shall obtain all regulatory agency permits and approvals as required, including, but not necessarily limited to, those from the Township of Spring Lake, Minnesota Pollution Control Agency, Army Corp of Engineers, Minnesota Department of Natural Resources, Minnesota Department of Transportation, Scott County, Watershed, etc. prior to beginning of construction, etc.

The following are specific requirements related to the development of grading/erosion control plans for the proposed subdivision and adjacent land within 200' unless noted otherwise:

1. Grading/erosion control plans designed and signed by a civil engineer or a land surveyor registered in the State of Minnesota.
2. Show existing and proposed storm sewer.
3. Show proposed borrow pits and stockpile areas.
4. Show lot corner elevations and bench marks utilized.
5. Existing contours shall be at 1' or 2' intervals to a mean sea level datum (dashed lines). The contours shall extend beyond the proposed plat boundaries 150' or more to completely show the limits of a drainage basin(s) not fully contained within the proposed plat.
6. Proposed contours shall be at 1' or 2' intervals to a mean sea level datum (solid lines).
7. Graded slopes may be a maximum of 33% (3:1) and minimum of 2%.
8. Show ponds, wetlands, lakes, streams, or marshes.
  - Show high water level (HWL) for ponds.
  - Show the Outlet Elevation and HWL for ponds and wetlands.
  - Show OHWL elevation and DNR pond number if applicable.
  - Storage volume proposed.
  - Drainage area boundaries.
  - Show and define areas that will be seeded and mulched, sodded (one row behind the back of curb), or seeded with blanket. Common drainage swales must be seeded and blanketed at a minimum. Specify seed type on the construction plans.
  - Show Wetland Buffer.
9. Show existing and proposed building and driveway footprints.
10. Show house pads with house style and lowest floor elevations, garage elevation and walkout elevation. Include a legend for these items. Elevations must be in accordance with the requirements set forth in the County's Zoning Ordinance.
11. Driveways shall be designed at a minimum grade of 2% and a maximum grade of 10%, unless otherwise approved by the Township.
12. All driveways entering a paved road shall be paved (bituminous or concrete or paver brick) within the right-of-way. Alternative low impact surface treatments may be considered on a case by case basis.
13. Show proposed erosion control, including silt fence and heavy-duty silt fence locations. Heavy-duty silt fence is required around all ponding areas and wetlands. Silt fence is required in other areas as needed to keep any soil runoff within the property.
14. Show emergency overflow routes from all low points and ponds and show high point elevation along emergency overflow routes. Show directional flow arrows. Either sod or seed with fiber blanket shall be placed in these areas to protect from erosion.
15. Show removal of all trees and brush below the controlled water level that will be impacted from existing and newly created ponding areas. In the development of any subdivision or ponding area, the developer is responsible for the removal of all significant vegetation (trees, stumps, brush, debris, etc.) from any and all areas which would be inundated by the designated controlled water elevation (Outlet Elevation) of any required ponding easement as well as the removal of all dead trees, vegetation, etc., to the HWL of the pond.
16. Show or define access routes for maintenance purposes to all inlets, outlets, manholes and lift stations at ponding areas.
17. Show limits of clearing and grading.
18. Show 5 year and 100 year design drainage boundaries. Show acreage of each drainage area/watershed.

19. Erosion control shall at a minimum observe standards established in the following reports: "Protecting Water Quality in Urban Areas" (Best Management Practices for Minnesota), "National Urban Runoff Program" (NURP), National Pollutant Discharge Elimination System / State Disposal System (NPDES/SDS) General Stormwater Permit and the "Engineering Design Standards" for the Township of Spring Lake or as modified herein.
20. Show all lot and block numbers.
21. Show all street names.
22. Show centerline street elevations every 100-feet and at high and low points. Also show street grades.
23. Show typical lot detail indicating where lot and house elevations are.
24. Show typical street section.
25. Show drainage arrows at high points and major grade changes.
26. Show existing and proposed easements and outlots.
27. Wetland boundaries must be accurately shown along with the name of the person or company who delineated the wetland boundaries.
28. A grading as-built is required to be submitted and reviewed by the Township prior to the issuance of building permits.
29. Appropriate behind the curb erosion control.
30. A minimum of 4" of topsoil (w/minimum 15% organic) must be applied to all disturbed areas of the development prior to seeding or sodding.
31. Prior to seeding or sodding, turf areas must be tilled to a depth of 2'.

### **STREETS/TRAILS**

Streets shall conform to the most recent editions of "Mn/DOT Standard Specification for Highway Construction", "Mn/DOT Road Design Manual", "Minnesota Manual on Uniform Traffic Control Devices for Streets and Highways" or as modified herein and the Township's most recent Standard Detail Plates, general specifications and comprehensive transportation plans.

The developer shall obtain all regulatory agency permits and approvals as required including, but not necessarily limited to, those from the Minnesota Department of Transportation, Scott County, etc. prior to beginning of construction.

The following are specific requirements related to the design of street construction:

1. Street construction materials shall be in conformance with the Minnesota Department of Transportation, Standard Specifications for Construction, 2005 Edition and all subsequent revisions, except as specifically altered or modified herein.
2. Geotextile Fabric - Shall be installed after completion and approval of subgrade if required by the Township Engineer. Geotextile fabric shall be a non-woven fabric consisting of polymeric filament or yarns such as polypropylene, polyethylene, polyester, polyamide or polyvinylidene chloride, formed into a stable network such that the filaments or yarns retain their relative position to each other. The geotextile shall be inert to commonly encountered chemicals, resistant to ultraviolet radiation, and conform to the properties in the following table:

<b><u>Geotextile Property</u></b>	<b><u>Test Method</u></b>	<b><u>Value</u></b>
Grab Tensile Strength, lbs., min Either principal dir	ASTM-D-1682 Method 16 using 8" x 4" specimens 1" wide x 2" long clamps at 12 in./min. on a CRE type machine	180
Grab Tensile Elongation, %, max.	ASTM-D-1682	60
Burst Strength psi, min.	ASTM-D-751 (Diaphragm Method)	290
Trapezoid Shear Strength, lbs., min. (any direction)	ASTM-D-1117	50
Puncture Strength lbs., min.	ASTM-D-751 5/16" diameter hemispherical tip steel cylinder centered within ring clamp	75
EOS (U.S. Sieve)	AASHTO M-288	70-100
Permeability, cm/sec	Constant Head (50 mm)	0.20

Geotextile fabric shall be Phillips Supac 8-NP, Amoco Propex 4557, Hoechst Trevia 1127, or equal. All splices shall be overlapped a minimum of 24 inches or seamed (sewed, glued, welded,) to produce equivalent fabric strength. Fabric shall not be left exposed to the sun for a period in excess of 3 days. Rips shall be patched with fabric lapped a minimum of 36 inches around the rip.

3. Bituminous material for mixture shall conform to Mn/DOT 3151 for asphalt cement AC-1 with 85/100 penetration. Aggregate shall meet the requirements of Mn/DOT 3139 for BA-1 wear course and BA-2 base/binder course.
4. Bituminous mixture shall conform with Mn/DOT 2360. The asphalt and bituminous mixture shall be per the Standard Detail Plates
5. Bituminous Tack Material shall be in conformance with Mn/DOT Section 3151.2.E, for Emulsified Asphalt.
6. Material for concrete curb and gutter shall be accordance with Mn/DOT Section 2531. Reinforcing rods are required for 10' transitions to and from catch basins and concrete valley gutters.
7. All local streets shall meet 20-mph design standards
8. All collector streets are to be designed to meet or exceed Mn/DOT standards for 45-mph. Vertical curves shall be provided for all grade changes greater than 0.5%.
9. Street section design shall meet standards contained in the Township Standard Detail Plates



10. Where possible, the Township will require minimization of cul-de-sac measured from centerline to centerline to the center of the cul-de-sac.
11. Streets shall intersect at right angles unless otherwise approved by the Township.
12. Barricades in accordance with the Minnesota Manual on Uniform Traffic Control Devices and the Standard Detail Plates shall be placed on all dead end streets.
13. No street grade shall be less than 0.5%. The maximum allowable grade for a 30 mph design speed is 6% for flat topography and 7% for rolling topography. At intersections, the street grade shall not exceed 2.0% for the first 50' approaching said intersection unless otherwise approved by the Township. The 50' is measured from the curb line of the intersected street.
14. In cul-de-sacs, the gutter grade shall conform to the Standard Detail Plates.
15. Soil boring information shall be submitted to the Township.
16. Removal and replacement of unsuitable subgrade materials will be subject to the recommendations of the soils engineer and the approval of the Township.
17. Cul-de-sacs are required on all "dead-end" public streets. Temporary "dead-end" situations associated with phased development shall conform to the temporary turn around show in the Standard Detail Plates.
18. New residential subdivisions will require mountable curb and gutter when curb and gutter is used. B618 curb and gutter are required in all intersection radii and catch basin transitions.
19. A 20' minimum intersection radius shall be used on residential streets. A 30' minimum intersection radius shall be used for collector roads. Minimum grade around curb radii is 0.5%.
20. A concrete pedestrian curb ramp is required when sidewalk or pathway intersect with curbs. The ramp shall be constructed according to the latest revision of Township Standard Plates.
21. The design and construction of sidewalks and trail ways shall be in accordance with the Township's Standard Detail Plates.
22. Street signs, stop signs or other traffic control signage shall be paid for and include installation per "Minnesota Manual on Uniform Traffic Control Devices for Streets and Highways," Mn/DOT, and Township of Spring Lake Standard Detail Plates by the developer. The signs shall be placed at all intersections or at such other locations as designated by the Township Engineer. All signs must be installed prior to final building inspection approval or earlier if necessary as determined by the Township Engineer.
23. Street lighting systems shall be installed at the developer's expense and as approved by the Township Engineer.
24. The wear course shall be placed after the completed utility construction has gone through at least one freeze-thaw cycle. Dependent upon the home construction in the area, additional time may be required before the wear course may be placed, at the discretion of the Township Engineer.
25. The Township requires soil borings for the determination of an R-value to be used in calculating the total granular equivalency (G.E.) of a street's design requirements. The R-value is a measure of embankment soil resistance strength expressed on a scale of 1 to 100. Soil investigation should also include the observation of ground water in the boring.
26. Concrete valley gutters will not be used unless approved by the Township Engineer.  
The boulevard (right-of-way) shall not contain any landscaping other than a ground cover.
27. Retaining walls over 4 feet in height, located on private or public property shall be designed by a Minnesota Registered Professional Structural Engineer.

Certain retaining walls will require a Building Permit. Retaining walls that require a building permit shall be constructed in accordance with plans and specifications prepared by a structural or geotechnical engineer licensed by the State of Minnesota. Following construction, a certification signed by the design engineer shall be filed with the Building Official evidencing that the retaining wall was constructed in accordance with the approved plans and specifications. All retaining walls identified on the development plans or by special conditions referred to this Contract shall be constructed before any other building permit is issued for a lot on which a retaining wall is required to be built.

28. The design and construction of sidewalks and trailways shall be in accordance with the Township's Standard Plates
29. The developer shall establish turf and control all erosion on all disturbed areas and will maintain until the Township accepts the project.
30. No residential driveway shall be permitted within 50 feet of the end of the radius of an intersection of any two streets.
31. The Developer shall pay for the cost of sealcoating the project roads. The Township will collect the cost for the treatment at the time of the execution of the Developer's Agreement, and the Township will complete this work through their annual road maintenance project.

# Construction Plan Standards

In order to standardize construction and achieve uniformity, the guidelines listed below shall be followed.

## **GENERAL REQUIREMENTS**

1. Upon approval of the plans, two full size sets and two half-size sets will be submitted to the Township.
2. A standard title sheet shall be prepared for each project plan set. In addition, each plan sheet shall be clearly labeled with sheet number, identification of improvement, and other appropriate information.
3. A location plan shall be prepared on the title sheet, at a legible scale, indicating the entire project. An index of the construction plan sheets involved with the work and their location within the project shall be shown on the plan.
4. All detail drawings shall be on a separate sheet or sheets and referenced to the proper sheet. Township Standard Details shall be utilized wherever feasible.
5. Scale - Horizontal Scale - 1"= 50', Vertical Scale - 1"= 10'
6. All parcels shall be properly labeled with lot and block numbers and plat name, or parcel identification numbers (PIN) in unplatted areas.
7. All streets shall be clearly labeled.
8. All match line breaks shall be clean with reference points clearly marked. All plan views which are broken by a match line shall be on the same or consecutive sheets if possible.
9. Existing public utilities and other topography shall be shown, stationed and labeled as existing.
10. Locations of existing gas, electric, cable TV and telephone lines shall be shown in accordance with Minnesota State Statute 216.D.
11. Right-of-way and pavement or curb and gutter alignment data shall be shown.
12. All plans shall have properly placed north arrows for each plan sheet. Whenever possible, the north arrows should point up or to the left of the sheet.
13. Benchmarks shall be placed on all plan and profile sheets. A minimum of two benchmarks shall be provided.

## **SPECIFIC REQUIREMENTS**

1. The profile shall be directly below the plan, on the same sheet, with the stationing aligned as closely as practical. Stationing shall be shown on the plan view as well as on the profile.
2. All manholes, flared end sections and hydrants shall be numbered in both plan and profile views.
3. Storm sewer plans shall indicate boundary or limits of ponding easements, pond outline, normal water elevation, high water elevation, acre-feet of storage, discharge rate of flow, and outlet control device for each pond.
4. A minimum of two benchmarks must be included within the construction plans.

5. A storm sewer schedule must be included with the construction plans. Include the structure number, size of structure, and proposed casting number in the schedule. Include all skimmer structures, flared end sections, and sumps in this schedule.
6. Utility crossings shall be shown in the plan and profile views.
7. Show flow direction arrows in the plan section of the plan and profile.
8. If storm sewer bends are utilized, provide stationing for the beginning and end points of the bends. Provide the radius of the bend utilized.
9. The utility construction plans and street construction plans shall show the centerline stationing.
10. The street construction plans shall include the typical street sections utilized.
11. Each street plan sheet shall show right-of-way width, street width (back of curb to back of curb or edge of pavement), and a typical radius dimension at intersections.
12. Proposed horizontal alignment data shall be shown on the street plan sheets.
13. Existing and proposed vertical alignment data shall be shown on the street plan sheets.
14. The street construction plans shall show directional arrows for drainage. High points and low points shall be labeled as such.
15. Show ponds, wetlands, lakes, streams, or marshes.
  - Show the Outlet Elevation and HWL for ponds and wetlands.
  - Show OHWL elevation and DNR pond number if applicable.
  - U.S. Fish & Wildlife classification if applicable.
  - Show proposed pond storage volume.

# Record Plan Requirements

As-built plans are required for all public and private improvements.

After the completion of Developer installed public or private improvements, the Township Engineer shall be provided with two sets of record drawing plans of the project for review purposes.

Upon final approval of the record drawing plans of the project, the Township Engineer shall be provided with and 2 half size sets (11"x17") of the approved record drawing plans of the project. All record plans shall be clearly legible drawings, accurately drawn to scale. Proper notes and statements as required in this manual shall be placed on the plans.

The Township shall be provided with 3 half size sets of the approved record drawing plans of the project. The Township will also be provided with the as-built drawings on disk in the Township approved format as follows:

## **ELECTRONIC AS-BUILTS**

1. Required on compact disk.
2. All information must be in AutoCAD DWG format.
3. Approved final plat sheets submitted in Scott County coordinates.
4. As-built construction plan sheets shall have descriptive layer names or a key for the layers names.
5. Overall development plan with all utilities (MHs, FES, CBs, GVs, etc.) in Scott County coordinates.
6. Show Scott County monuments that were used for the survey.

After completion of construction, all manholes, catch basins, and other elements of the project shall be re-measured with an as-built field survey. The plans shall be corrected and modified to show the correct distances, elevations, dimensions, and any other change in the specific details of the plans. All changes and modifications on the record plan shall be drawn to scale to accurately represent the work as constructed. Incorrect elevations, distances, etc. shall be crossed out from the original plan sheets and corrected as necessary to complete the record plan. Do not remove the proposed elevations from the plan sheets.

At a minimum record plans shall include:

## **GENERAL**

1. All construction contractors' names should be noted on each page.
2. Record Plan stamp with date should be shown on each page.

## **GRADING PLAN**

1. Existing ground elevations at all lot corners.
2. Spot elevations at all house pads (hold down elevations).
3. Elevations of tops and bottoms of retaining walls

4. Spot elevations of pond bottom (50' maximum grid).
5. Drainage and utility easement and outlot spot elevations.
6. Pond water elevations and date taken.
7. Prior to close out, as-builts of ponding areas must be done to verify depths after house construction is complete.
8. Location and elevations along all swales, emergency overflows, wetlands, wetland mitigation areas if any, ditches, location and dimensions of borrow areas/stockpiles;

**NOTE:** The as-built grading plan does not replace the approved grading plan. This plan is merely a tool to observe the grading of the area prior to home construction. The approved grading plan will still be utilized for all home construction purposes.

#### **STORM SEWER**

1. As-built elevations (invert & rim), pipe lengths, and grades for all lines.
2. Note describing pipe type and size for each run.
3. Cross out proposed elevations and write as-built above –DO NOT remove proposed elevations from plans.
4. Ties to all storm sewer bends, if utilized. Ties shall be provided to the beginning and end points, using the following priorities:
  - Manholes.
  - Catch basins.
  - Neighboring structures, with the address noted.
  - Buildings or other permanent structures (bridges, telephone boxes, pedestals, transformers, etc.).
  - Power poles, streetlights, etc.
5. As-built plans on all ponding areas are required. Plans shall indicate finished contours at two-foot intervals, normal water elevation, high water elevation, and the acre-feet of storage for each ponding area along with the final storm sewer plans. Upon completion of pond construction, ponds shall be cross-sectioned to confirm that they have been constructed to the proper volume and shape. As-built record plans shall be prepared for all ponding areas just prior to closing project out.

#### **STREETS**

1. Show where fabric has been placed in the streets on the plan portion of the as-builts.
2. Show any areas where subgrade correction was needed, type of correction, and the size of the corrected area. Include ties to nearby structures.
3. Show location of all draitile on the plans.

# Construction Requirements

No construction will commence on any project until the construction plans for the improvements are approved by the Township Engineer.

## **SUBDIVISION MONUMENTATION**

Minnesota State Statute requires subdivision monumentation of all plats within one year of recording with the County. The Township requires all subdivision monumentation necessary to provide control for the installation of public infrastructure improvements be established prior to issuance of the "Notice to Proceed".

## **SUGGESTED CONSTRUCTION STAKING GUIDELINES**

### **STORM SEWER**

1. Line and grade stakes shall be set every 25' for the first 100' out of the downstream manhole, and every 50' thereafter to the next manhole or catch basin.
2. An offset hub and line reference stake to back of curb shall be set for all catch basins and catch basin manholes.
3. Catch basin top and invert elevations and manhole top elevation and upstream and downstream invert elevations shall be shown on the cut sheets.
4. Cut sheets shall be provided to the Township for all storm sewer construction.

### **STREETS**

1. When centerline stakes are set for grading subgrade, cut sheets shall be provided.
2. Line and grade stakes shall be set every 25' and for all beginning, mid and end radius points of the curb at street intersections.
3. Cut sheets shall be provided to the Township for all curb and gutter construction.

Note: All cut sheets must identify bench marks used, bench mark elevations, actual hub elevations, proposed elevations, and cuts or fills for all entries.

It is also imperative that the contractor and project inspector for the Township have cut sheets in hand *prior to* construction. The Township will order contractor to cease working whenever this requirement is not met.

## **INSPECTION**

It is the policy of the Township of Spring Lake that any construction activity within the Township be monitored / inspected by Township staff personnel or a designated representative on behalf of the Township. The developer is responsible to have a representative from their engineering firm provide adequate field inspection.

## **TESTING REQUIREMENTS**

In order to assure quality materials and workmanship, the following tests shall be required:

### **STORM SEWER**

1. Pipe Class - Pipe class to be stamped on pipe, certification documentation may be required at the discretion of the Township Engineer.
2. Mechanical compaction tests required on all trench backfill and report copies submitted to the Township.

## **STREETS**

1. Soil Borings - Logs and recommendation required for subgrade correction, and section design. Soil boring reports must be included within the specifications.
2. Geotextile Fabric - Certification documentation. Show locations on record plans.
3. Compaction Tests - In accordance with Mn/DOT Section 2105, Paragraph F-1, Specified Density Method. Provide copies to the Township for permanent records.
4. Subgrade - Test rolling. Prior to placement of aggregate base, the subgrade shall be test rolled substantially in accordance with Mn/DOT Section 2111. The Township Engineer or authorized representative may allow some modification in the procedures outlined in Section 2111 to accommodate on-site equipment.
5. Tolerances - Physical inspection of subgrade and aggregate base by Engineering Technician. Tolerance limits include  $\pm 0.10'$  on subgrade and  $\pm 0.05'$  on aggregate base.
6. Aggregate Base Analysis - Gradation. The test results shall be supplied to the Township for permanent records.
7. Bituminous Mixture Analysis - Gradation, bituminous extraction, density. Asphalt content shall be determined by the design mix formula method, which shall be submitted to and approved by the Township Engineer prior to the work being performed. The test results shall be submitted to the Township for permanent records.
8. Concrete Analysis - Slump, air and compressive strength. The mix design must be submitted to the Township Engineer prior to the work being performed.
9. Testing of trail and sidewalk construction materials shall be the same as for street construction.

## **INSTALLATION REQUIREMENTS**

### **STORM SEWER**

1. Storm sewer pipe shall be installed in accordance with Mn/DOT Section 2501, except as modified or altered herein.
2. Pipe foundation, backfilling, and compaction shall be as outlined under Sanitary Sewer, Paragraphs 2 and 3.
3. Catch basin leads or storm sewers which cross the street in areas where soils are highly frost susceptible shall be backfilled in accordance with the guidelines outlined in the Mn/DOT Road Design Manual, Sections 8-6.02.08 and 8-6.02.09. A perforated drain pipe shall be placed on the bottom of the aggregate bedding, which shall drain into a catch basin structure. A detail for this construction shall be included on the plans. In lieu of the Mn/DOT method, the Township may consider an alternative design. Any alternative design shall be reviewed and approved by the Township Engineer.
4. Minimum catch basin lead is 12 inches in diameter.
5. Copies of any shop drawings shall be provided to the Township.
6. Maximum lateral adjusting ring offset is 3" (.25').

### **STREETS**

1. Street construction shall be in accordance with the following Mn/DOT specifications:
  - a) Common excavation and embankment - Mn/DOT Section 2105. Roadway embankments shall be compacted by the method described as "Specified Density Method" as outlined in Paragraph 2105.3.F1.



- b) Aggregate Base - Mn/DOT Section 2211. Compaction by "Specified Density Method" as outlined in Paragraph 2211.3.C1.
  - c) Plant-mixed Bituminous Base and Binder - Mn/DOT Section 2360. Design mix required to determine optimum oil content.
  - d) Plant-mixed Bituminous Wear - Mn/DOT Section 2360. Design mix required to determine optimum oil content. Steel wheel and rubber tired rollers required for finish.
  - e) Cold Weather Paving - Restrictions shall be in accordance with Mn/DOT Section 2331.3, Paragraph B. The Township Engineer shall make determinations on suitability of paving conditions.
  - f) Tack Coat - Installed in accordance with Mn/DOT Section 2357.
  - g) Concrete Curb and Gutter - Mn/DOT Section 2531. Curb section shall be as indicated on Plans in accordance with Standard Detail Plates. Joints shall be installed as outlined in Paragraph 2531.3.C. Maximum spacing of expansion joints shall be sixty (60) feet for hand formed curb; two hundred (200) feet for slip formed curb. Concrete curing and protection shall be in accordance with Paragraph 2531.3.G. If required by the Township Engineer:
    - Two (2) No. 4 reinforcing rods, 20 feet long, will be placed in the lower portion of the curb crossing all trenches.
    - Two (2) No. 4 reinforcing rods 10' long shall also be placed on each side of all catch basins located within the curb and gutter.
2. Street shall be constructed to not less than the minimum standards shown on the typical sections indicated on Standard Details. Subgrade conditions or other circumstances may require a larger section.
  3. Prior to placement of geotextile fabric (if required) and base course, the Contractor shall test roll the street subgrade. The Contractor shall provide a loaded tandem axle truck with a minimum gross weight of 25 tons and a weight ticket for the test roll vehicle if required by the Township Engineer. The test rolling shall be done under the direction of the Township Engineer. The Township may require test rolling of the aggregate base, once the base section has been constructed.
  4. After acceptance of test rolling and completion of the tolerance of subgrade, a geotextile subgrade stabilization fabric shall be installed (if required) in accordance with manufacturer's recommendations.
  5. Subsurface drain pipe shall be installed per the Standard Detail Plates and at other locations as determined by the Township Engineer in the field.
  6. It is desirable for the Developer to complete the street subgrade, aggregate base, curb and gutter and bituminous base course within the same construction season as the utility installation. The bituminous wear course shall be completed after a minimum of one freeze-thaw cycle after utility construction is complete.
  7. If the Developer is allowed to install the first layer of bituminous in the same season as the utilities, all castings within the roadway shall be adjusted to a point 1/2 inch below the level of the bituminous base surface, and readjusted later prior to placement of the final wear course. Ramping of castings will not be permitted.
  8. After placement of the bituminous base course and prior to placing the bituminous wear course, the Developer shall repair, replace and/or correct any and all settlements, cracks, breakups, markings, scars, or other damage or abuse caused by construction activity. Curb and gutter will be marked out by the Township for removal and replacement.

9. The Township will plow snow on Developer's streets only if at least one course of bituminous surfacing is in place and all castings within the roadway are adjusted to proper elevation and crown.
10. Before any excess excavation material is deposited on private property, the Contractor must get permission in writing from the property owner. Special care is directed to areas of surplus material disposal that may involve future buildings or foundations.

#### **TRAILS AND SIDEWALKS**

1. Trails and sidewalks shall be constructed in accordance with "Bikeway Design Manual, State of Minnesota Department of Transportation" and the "Parks and Trails Plan, Township of Spring Lake, Minnesota".
2. Provide positive surface water drainage away from the trail way where practical with shallow drainage swales or ditches, culverts and/or storm sewer as required. For drainage purposes, the absolute minimum slope is 0.5%. Use 0.02' per foot minimum cross-slope or crown; 0.04' per foot is maximum cross-slope.
3. Shape and compact subgrade to 100% standard proctor density. Excavate and remove all topsoil, black dirt, peat, muck or silt soils from beneath pathway; backfill with select grading material. Subgrade of trail way to be a minimum of two feet above water table.
4. Avoid sharp or sudden changes in horizontal and vertical alignment. Provide adequate site distance for bicycles at intersections and on vertical changes in alignment. Provide clearance for vertical obstructions (trees, power poles, signs, etc.); four foot minimum for bicycle facilities.
5. Bicycle trails are to be marked and signed in accordance with the Minnesota Manual on Uniform Traffic Control Devices, latest edition.
6. Minimum standards shall be increased as necessary where required by poor subgrade soil, traffic volumes, hazardous conditions, or other special circumstances. Extra width and/or flatter curves may be required on long downhill slopes for additional reaction space.
7. Parklands must be sodded or seeded (as determined by Engineer) and maintained by developer until final acceptance of the project is completed.

# Final Project Completion/Acknowledgment

## **ACCEPTANCE OF UTILITIES**

Once the utility construction and all related work order items are complete and a written request is made by the Developer, the Township will accept the utilities in the form of a resolution by the Township Board. Once the utilities are accepted, the warranty period for the utilities will begin.

## **ACCEPTANCE OF STREETS**

Once the street construction and all related work order items are complete and a written request is made by the Developer, the Township will accept the project in the form of a resolution by the Township Board. Once the project is accepted, the warranty period for the streets will begin.

# Building Requirements

## **ISSUANCE OF BUILDING PERMITS**

1. The Township will advise the Building Official not to issue building permits for structures or buildings in new subdivisions until the following items have been successfully completed or unless otherwise identified in the developer's agreement.
  - a) Utilities have been installed and all tests have passed.
  - b) Final site and boulevard grading including seeding and erosion control is completed to the satisfaction of the Township Engineer.
  - c) The first lift of bituminous (with iron raised and adjusted) is placed adjacent to the property and all the way to an adjoining road. However, the Township Engineer is authorized to waive this requirement when weather related circumstances prevent completion of street projects before the end of the construction season. The Developer is responsible for maintaining said streets in a condition that will assure the access of emergency vehicles at all times when such a waiver is granted.
  - d) All street signs must be installed.
  - e) As-built grading plan submitted and reviewed by the Township.
2. The issuance of individual building permits for residential property shall be based on the subdivision grading plan approved by the Township as part of the development site plan process. Changes to the actual grading of the lot or structure type noted on said plan shall be subject to a separate review and approval process by the Township. To initiate this review process, a revised grading plan clearly indicating proposed changes to the approved grading plan shall be submitted for review and approval before the building permit is issued. Further, the developer shall be required to acknowledge the revised plan as a modification to the original overall site grading plan. It is the Township of Spring Lake's intent to assure the revised plan fits the lot, is consistent with area development and does not negatively impact adjacent property or structures.
3. Commercial, residential and industrial building permit applications shall be accompanied with a Certified Survey of the lot, locating all existing and proposed buildings, outlining all setbacks, setting the first floor elevation and indicating the utility connection points.
4. Prior to issuance of building permits, wetland buffer monuments shall be placed in accordance with the Township's policy. The monument design shall be per the Standard Detail Plates.

## **ISSUANCE OF OCCUPANCY PERMITS**

1. No structure or building shall be occupied without first obtaining an Occupancy Permit from the Building Official.
2. Occupancy Permits shall not be issued until permanent sanitary sewer, water, and electric services are connected to the building and in operating condition, and they have been inspected and approved.
3. Occupancy Permits shall not be issued until there is suitable street access to the parcel being occupied. Such suitable street access shall consist of a completed subgrade, aggregate base, and the base course of bituminous.
4. When one layer of bituminous has been installed, manhole castings must be adjusted to appropriate height.

5. Front yard, sides and all easements shall be sodded in accordance with the Township's Landscaping Ordinance.

**BUILDING CONSTRUCTION REQUIREMENTS**

1. The Developer shall be responsible for all street maintenance until the streets are accepted by the Township.
  - a. Warning signs shall be placed when hazards develop in streets to prevent the public from traveling on same and to direct attention to detours.
  - b. If and when streets become impassable, such streets shall be barricaded and closed.
  - c. In the event residences are occupied prior to completing streets, the Developer shall maintain a smooth surface and provide proper surface drainage to insure that the streets are passable to traffic and emergency vehicles.
  - d. The Developer shall be responsible for keeping streets within and without the subdivision swept clean of dirt and debris that may spill, track, or wash onto the street from Developer's operation. The Developer shall contract for street cleaning within and immediately adjacent to the development. At a minimum, scraping and sweeping shall take place on a weekly basis. A copy of this contract shall be approved by the Township before grading is started. The contract shall provide that the Township may direct the contractor to clean the streets and bill the Developer.
  - e. The Developer may request, in writing, that the Township keep the streets open during the winter months by plowing snow from the streets prior to final acceptance of said streets. The Township shall not be responsible for repairing the streets because of snow plowing operations. Providing snow plowing service does not constitute final acceptance of the streets by the Township.
2. If a builder should need to cross a drainage & utility easement with a buried utility, the utility shall cross in a straight line and as close to perpendicular as is practical. The utility shall be marked with a trace wire and both ends shall be identified with a trace wire access box.

# Miscellaneous

1. The Developer's engineer is responsible for design changes and contract administration between the Developer and the Developer's contractor. Prior to starting construction, a representative of the Developer, a representative of the Consulting Engineer and a representative of the Contractor shall meet with the Township Engineer and other interested parties to discuss the method and means of supply, a work schedule as to the construction phases and a general review of the specifications and Township requirements. Within 10 days of the pre-construction conference, a written schedule of proposed construction activity, including estimates of time to complete each phase shall be established.
2. Proper notification of improvements shall be given by the Developer or his/her Engineer to the proper governmental agencies, watershed districts, area residents, etc, that could be affected by said construction. All necessary permits shall be obtained prior to commencing any work. All special requirements of the governmental agencies having jurisdiction over the work shall be complied with.
3. The Developer's Contractor shall furnish, erect and maintain temporary signs and barricades as provided in Mn/DOT Section 1710, "Traffic Control Devices" to protect the public. The Superintendent of Public Works shall be notified a minimum of 24 hours prior to the proposed partial blockage or closure of any street, alley or public right-of-way. No street or public right-of-way shall be closed without the proper approval of the Superintendent of Public Works.
4. It is the responsibility of the Developer's Contractor to protect and leave undisturbed markers or monuments set for the subdivision of land. In the event that any are destroyed, they shall be replaced at the Developer's and/or Contractor's cost.
5. The Developer shall immediately repair or replace, without additional compensation, any defective workmanship or material during the construction period, or within one year after the date of final acceptance of the work, regardless of prior inspections and approvals.
6. Township streets utilized for access or egress to and from the project site shall be kept free of dirt and other debris resulting from construction activity, including material delivery. Any damage to access or egress streets shall be repaired or corrected by the Developer at his expense. Adequate control of dust shall be maintained by the Developer's Contractor.
7. The Township will require the Contractor to submit a list of materials and respective suppliers as well as all tests of materials to the Township Inspector. Where material or labor supplied by the Contractor or Developer shall be rejected by the Township as defective or unsuitable, then such rejected material shall be removed, disposed of off the project site, and replaced with approved material. The work shall be completed again to the specifications and approval of the Township.
8. The Contractor shall supply the Township with a list of all subcontractors and material suppliers.
9. Reflector Language A single diamond shaped reflector panel shall be placed at the end of dead end street. All trees, stumps, brush, etc., shall be cleared within two (2') feet of the edges of trails. The exception will be only hardwood specimen trees or other exceptional items of high significant value, as determined by the Township Inspector.
10. The standard ten (10') foot utility and drainage easement adjacent to the street right-of-way shall be cleared and grubbed for the placement of utilities. The exception will be only hardwood specimen trees or other exceptional items of high significant value, as determined by the Township Inspector.
11. The Developer shall pay for and install all permanent street signage.



**STANDARD SPECIFICATIONS  
AND  
DETAIL PLATES**

**2017**

	<u>GENERAL</u>
GEN-1	STANDARD DETAILS INDEX
GEN-2	STANDARD DETAILS INDEX
GEN-3	INDEX OF REVISIONS
GEN-4	PERMANENT BARRICADE
GEN-5	TYPICAL PRIVATE UTILITY LOCATIONS
GEN-6	CROSSWALK LAYOUT
GEN-7	STREET NAME BLADE SIGNS - PUBLIC AND PRIVATE STREETS
GEN-8	REGULATORY SIGN DETAIL
GEN-9	STRUCTURE MARKER SIGNS
GEN-10A	MAILBOX INSTALLATION - URBAN
GEN-10B	MAILBOX INSTALLATION - RURAL
GEN-11	TYPICAL CUL-DE-SACS
GEN-12	WETLAND BUFFER SIGN

	<u>SECTION 1 - STORM SEWER</u>
STO-1	STORM SEWER MANHOLE
STO-2	STORM SEWER JUNCTION MANHOLE
STO-3	STORM SEWER JUNCTION MANHOLE WITH REINFORCED TOP SLAB
STO-4	CATCH BASIN MANHOLE
STO-5	2' X 3' CATCH BASIN
STO-6	PRECAST 27" DIAMETER SHALLOW DEPTH CATCH BASIN
STO-7	FLARED END SECTION AND TRASH GUARD
STO-8	RIP RAP AT OUTLETS
STO-9	PERFORATED DRAINTILE PIPE - BELOW CONCRETE CURB
STO-10	PERFORATED DRAINTILE PIPE - TRENCH DETAIL
STO-11	SEEPAGE COLLAR
STO-12	STANDARD SKIMMER STRUCTURE
STO-13	SKIMMER STRUCTURE WITH CONCRETE BAFFLE WALL
STO-14	TYPICAL POND BENCH DETAIL
STO-15	BEDDING METHODS FOR RCP OR DIP
STO-16	BEDDING METHODS FOR VCP OR PVC



STANDARD DETAILS

INDEX

SPRING LAKE TOWNSHIP

Last Revision:

JAN 2010

Plate No.

GEN-1



SECTION 2 - STREETS

- STR-1 CURB AND GUTTER
- STR-2 RESIDENTIAL DRIVEWAY OR ALLEY SECTION
- STR-3 COMMERCIAL DRIVEWAY SECTION
- STR-4 B618 CURB & GUTTER CONSTRUCTION AT CATCH BASIN
- STR-5 SURMOUNTABLE CURB & GUTTER CONSTRUCTION AT CATCH BASIN
- STR-6 CONCRETE VALLEY GUTTER
- STR-7 TYPICAL CURB RADIUS
- STR-8 TYPICAL SECTION FOR LOCAL STREET - RURAL SECTION
- STR-9 TYPICAL SECTION FOR LOCAL STREET - URBAN SECTION
- STR-10 TYPICAL SECTIONS FOR CONNECTOR AND COLLECTOR STREETS
- STR-11 TYPICAL DRIVEWAY
- STR-12 CONCRETE CURB & GUTTER TRANSITION
- STR-13 PEDESTRIAN CURB RAMP (PATHWAY/SIDEWALK)
- STR-14 TYPICAL SECTION FOR SIDEWALK ACROSS DRIVEWAY

SECTION 3 - EROSION CONTROL

- ERO-1A SILT FENCE - MACHINE SLICED
- ERO-1B SILT FENCE - HEAVY DUTY
- ERO-1C SILT FENCE - STANDARD
- ERO-1D SILT FENCE - J-HOOK
- ERO-2 EROSION CONTROL BLANKET INSTALLATION
- ERO-3 FLOATING SILT CURTAIN
- ERO-4A INLET PROTECTION - FOR CATCH BASIN BEFORE CURB CONSTRUCTION
- ERO-4B INLET PROTECTION - FOR CATCH BASIN AFTER CURB CONSTRUCTION
- ERO-4C INLET PROTECTION - FOR BEEHIVE CASTING
- ERO-5A DITCH CHECK - 3D VIEW FOR 5B, 5C, AND SPACING
- ERO-5B DITCH CHECK - ROCK WEEPER AND BIO WEEPER
- ERO-5C DITCH CHECK - SMALL CHECK DAM AND LARGE CHECK DAM
- ERO-5D DITCH CHECK - BIOROLL SILT DIKE
- ERO-5E DITCH CHECK - TRIANGULAR SILT DIKE
- ERO-6 FLARED END EROSION CONTROL
- ERO-7 ROCK CONSTRUCTION ENTRANCE
- ERO-8A TEMPORARY SEDIMENTATION BASIN - PIPE OUTLET
- ERO-8B TEMPORARY SEDIMENT BASIN - STANDPIPE OUTLET
- ERO-9 TEMPORARY SEDIMENT TRAP
- ERO-10 SLOPE TRACKING



STANDARD DETAILS

INDEX

SPRING LAKE TOWNSHIP

Last Revision:

JAN 2010

Plate No.

GEN-2

# INDEX OF REVISIONS

<u>DATE</u>	<u>PLATE</u>	<u>DESCRIPTION</u>
-------------	--------------	--------------------

.	.	.
.	.	.
.	.	.
.	.	.
.	.	.
.	.	.
.	.	.
.	.	.
.	.	.
.	.	.
.	.	.
.	.	.
.	.	.
.	.	.
.	.	.
.	.	.
.	.	.
.	.	.
.	.	.
.	.	.
.	.	.
.	.	.
.	.	.
.	.	.
.	.	.
.	.	.
.	.	.
.	.	.
.	.	.
.	.	.
.	.	.
.	.	.
.	.	.
.	.	.
.	.	.
.	.	.
.	.	.
.	.	.
.	.	.
.	.	.
.	.	.
.	.	.
.	.	.



STANDARD DETAILS  
INDEX OF REVISIONS

SPRING LAKE TOWNSHIP

Last Revision:  
JAN 2010

Plate No.  
GEN-3

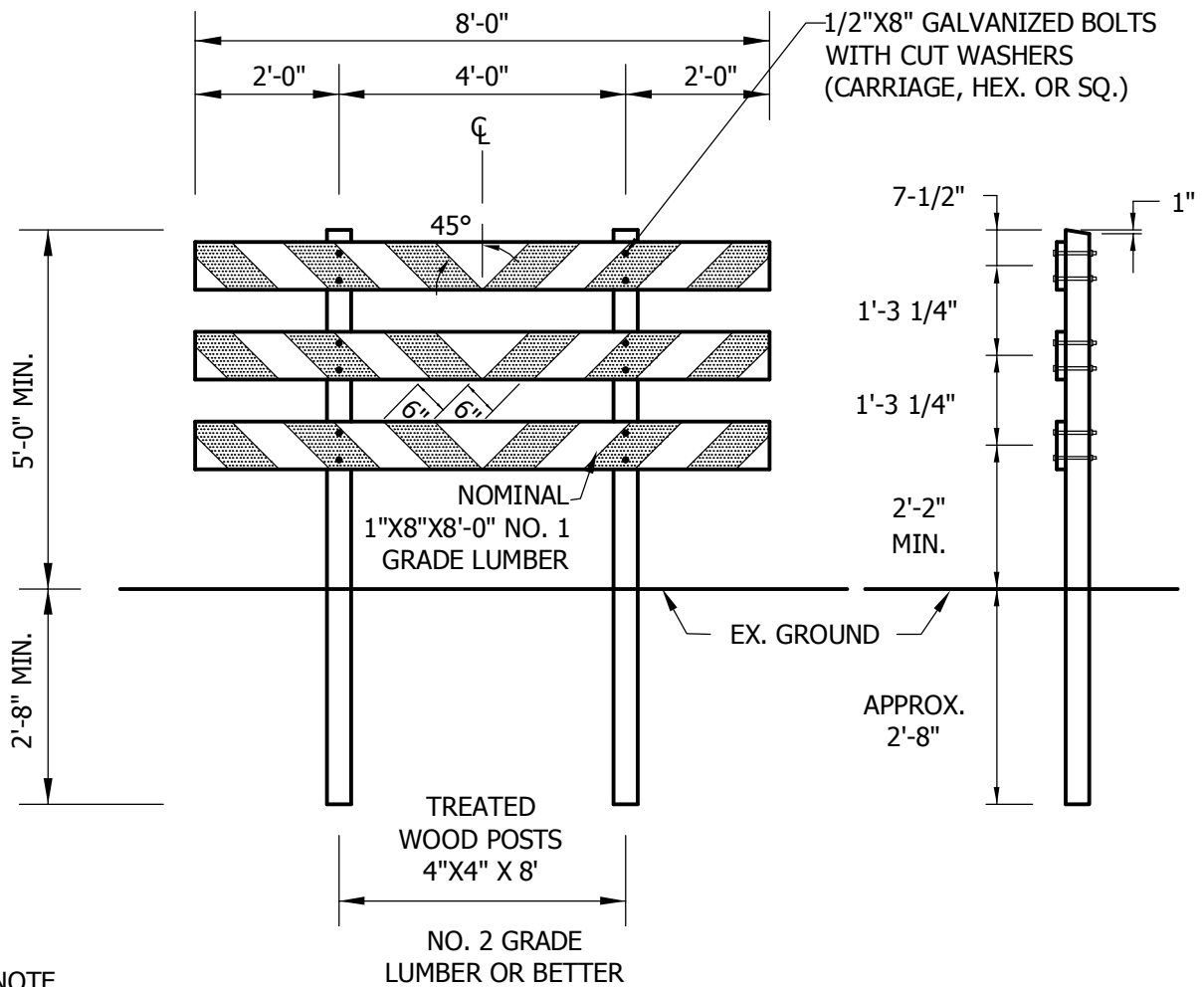

**NOTE**

THE BARRICADE BOARD FACE SURFACES SHALL BE FULLY REFLECTORIZED IN ALTERNATE SILVER-WHITE AND RED STRIPING, USING A REFLECTIVE SHEETING CONFORMING TO THE REQUIREMENTS OF SPEC. 3352.2A2B, STANDARD NO. 2.

PRIOR TO INSTALLING THE REFLECTIVE SHEETING, THE BARRICADE BOARDS SHALL BE GIVEN A COMPLETE COATING OF WHITE WOOD PRIMER PAINT FOLLOWED BY A SECOND COAT OF WHITE EXTERIOR APPLIED ONLY TO THE SURFACES NOT COVERED WITH REFLECTIVE SHEETING.

THE BARRICADE BOARDS SHALL BE COMPLETELY PAINTED AND REFLECTORIZED SHEETING APPLIED BEFORE BEING INSTALLED ON THE POSTS.

THE PLACEMENT OF THE BARRICADE SHALL BE 10'-0" FROM THE END OF THE BITUMINOUS ROAD WITH THE BARRICADE CENTERED ON THE ROADWAY FACING THE FLOW OF TRAFFIC.



**STANDARD DETAILS**  
PERMANENT BARRICADE

SPRING LAKE TOWNSHIP

Last Revision:

JAN 2010

Plate No.

GEN-4

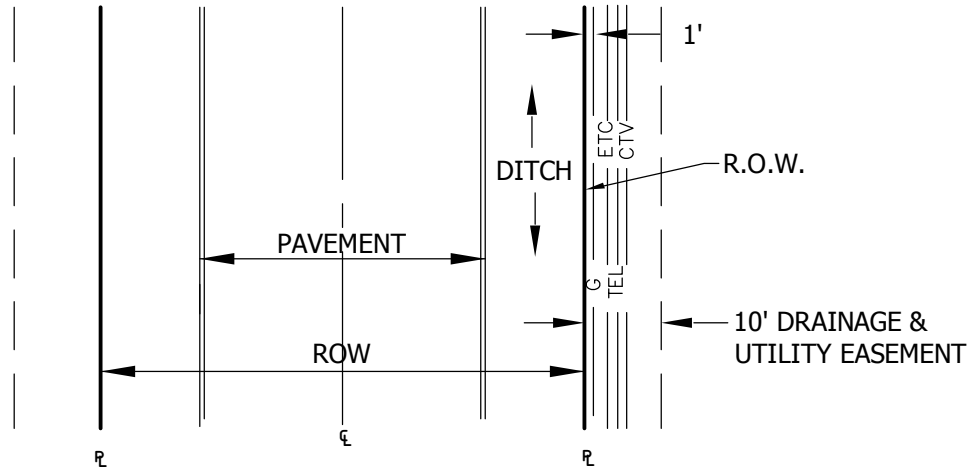

RURAL SECTION

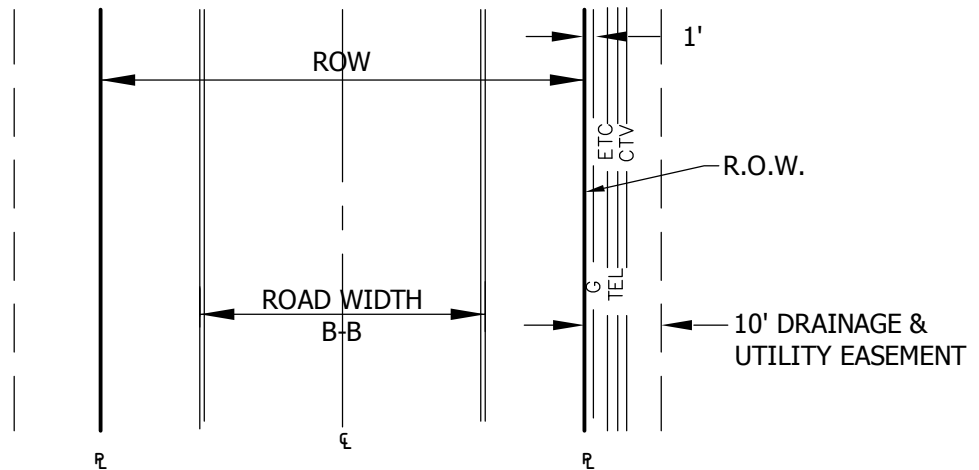

URBAN SECTION

PRIVATE UTILITIES SHALL BE PLACED  
IN ROAD SIDE DRAINAGE AND UTILITY  
EASEMENT IN "JOINT TRENCH".



**STANDARD DETAILS**  
TYPICAL PRIVATE UTILITY LOCATIONS

**SPRING LAKE TOWNSHIP**

Last Revision:

JAN 2010

Plate No.

GEN-5

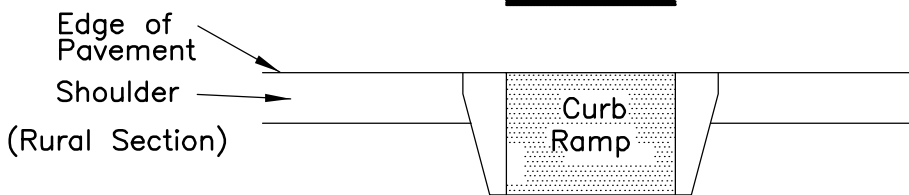
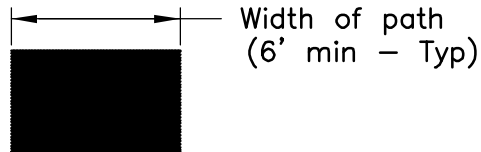
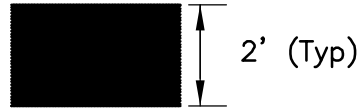
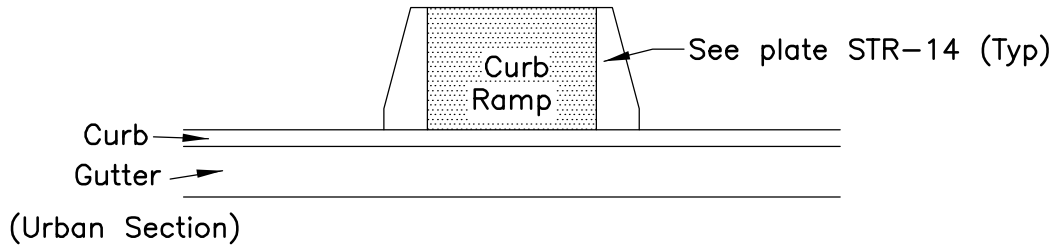

NOTE:

1. Crosswalk lines shall be solid white.
2. All pavement markings shall conform to latest version fo the Minnesota Manual on Uniform Traffic Control Devices (MMUTCD)



**STANDARD DETAILS**  
CROSSWALK LAYOUT

Last Revision:

JAN 2010

Plate No.

GEN-6

SPRING LAKE TOWNSHIP



ALL LETTERS UPPER CASE, 6"

PUBLIC

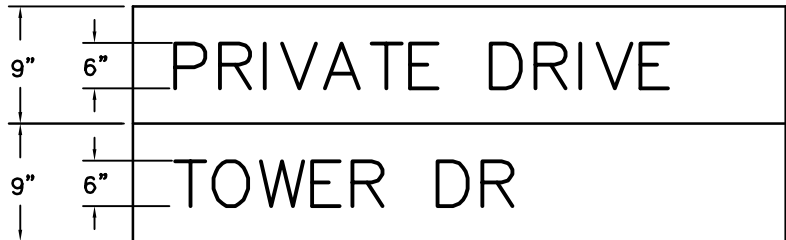

ALL LETTERS UPPER CASE, 6"

PRIVATE

STANDARD CONSTRUCTION NOTES FOR STREET NAME SIGNS

1. All street signs shall be high-intensity, double-faced extruded blades.
2. All letters or suffix shall be uppercase.
3. Contractor shall submit shop drawings for street name blades prior to fabrication.
4. Street sign posts shall be 12 feet long, min. 3 feet driven into the ground anchor base w/ 2 3/8 brace Simpson strong tie or equal.
5. Sign posts for street name blade signs shall be round, tubular aluminum or hot-dipped galvanized steel, outside diameter 2-3/8 inches, wall thickness 0.080 inches.
6. All public street name blades shall be "green" in color. Lettering on all street name blades shall be high intensity, "white" in color.
7. All private street name blade signs shall be "white" in color, Lettering on all street name blades shall be high intensity "black" in color.
7. All private street name blade signs shall be accompanied by a second blade sign of the same color scheme saying "Private Drive".



STANDARD DETAILS

STREET NAME BLADE SIGNS  
PUBLIC AND PRIVATE STREETS

SPRING LAKE TOWNSHIP

Last Revision:

JAN 2010

Plate No.

GEN-7

Sign Name	Designation	Size
STOP	R1-1	30"x30"
YIELD	R1-2	36"x36"x36"
SPEED LIMIT	R2-1	24"x30"
NO PARKING	N/A	12"x18"

Notes:

1. Design shall conform to these requirements except as otherwise approved by the Township Engineer.
2. Sign shall be reflectorized as per MNDOT 3352.2A2g, Type XI "Diamond Grade 3 - DG3"
3. Sign shall be constructed of aluminum per MNDOT 3352.2A1

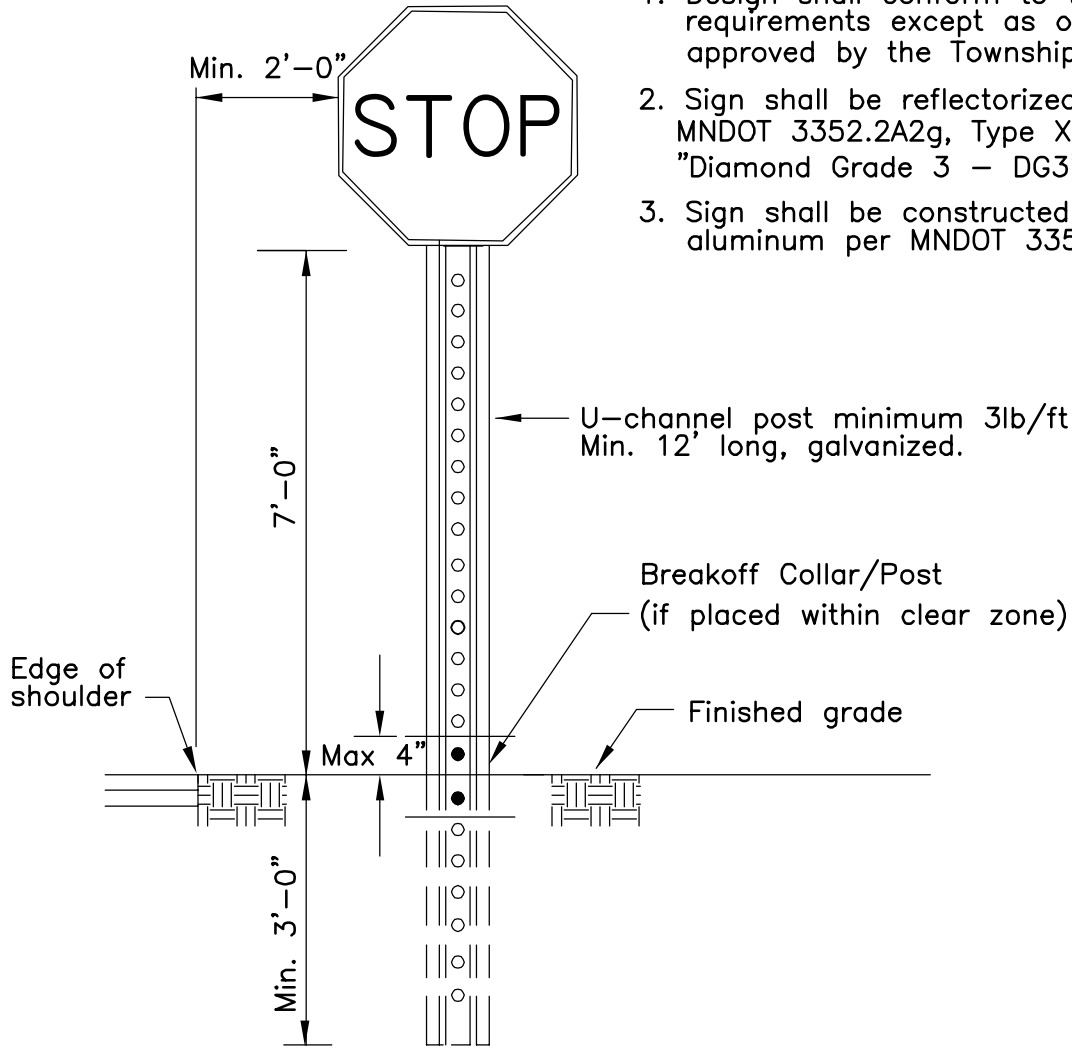

Installation shall be in compliance with the latest version of the MnMUTCD.



**STANDARD DETAILS**  
 REGULATORY SIGN DETAIL

**SPRING LAKE TOWNSHIP**

Last Revision:  
 APR 2017

Plate No.  
 GEN-8

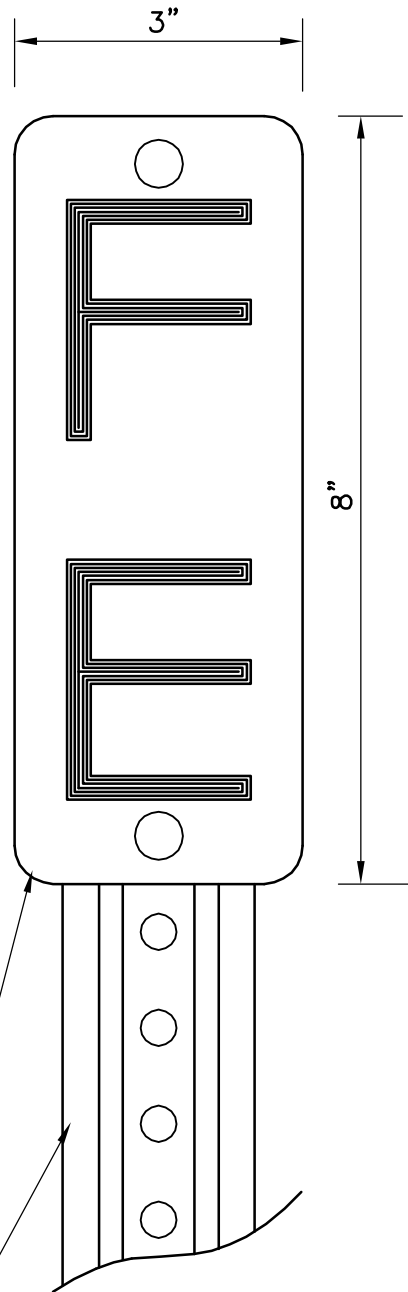

U-Channel post, Minimum 3 LB./FT.  
6'-6" long.

0.063" Thick aluminum sign. Black letters  
on white high intensity reflectorized background.



**STANDARD DETAILS**  
STRUCTURE MARKER SIGNS

SPRING LAKE TOWNSHIP

Last Revision:

JAN 2010

Plate No.

GEN-9



HEIGHT - 48 INCHES ABOVE STREET LEVEL

HAVE BOX EXTEND AS FAR IN FRONT OF SUPPORT POST AS POSSIBLE. (THIS PREVENTS POSSIBLE SNOW PLOW DAMAGE).

ADDRESS MUST BE ON SIDE OF BOX FROM WHICH CARRIER APPROACHES IN LETTERS ABOUT ONE INCH HIGH. (OR ON FRONT WHERE BOXES ARE GROUPED).

BOX MUST BE LOCATED SO CARRIER CAN SERVE WITHOUT LEAVING VEHICLE.

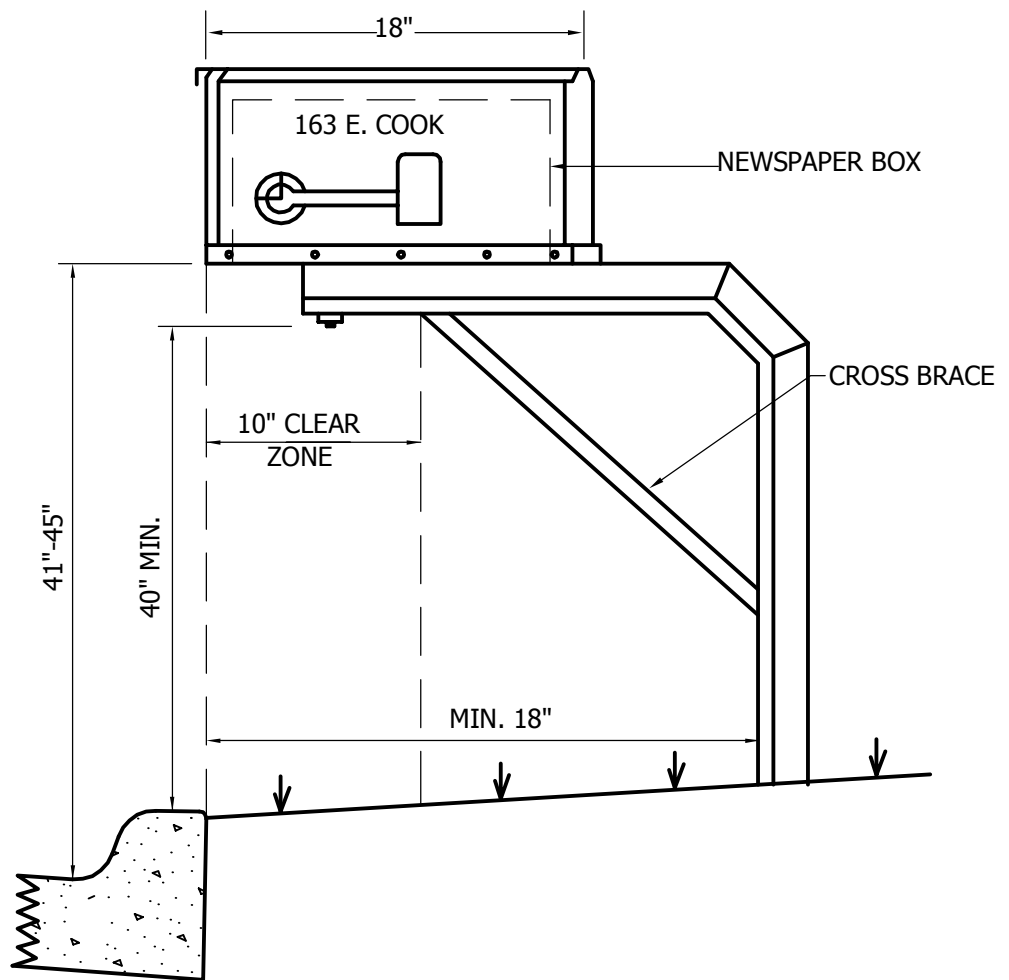

SIDE VIEW

**NOTES:**

MAILBOX SHOULD NOT EXTEND BEYOND BACK OF CURB.

ALL POSTS TO BE A MINIMUM OF 18" BEHIND BACK OF CURB.

DIMENSIONS AS PER U.S. POSTAL SERVICE

NEWSPAPER BOX

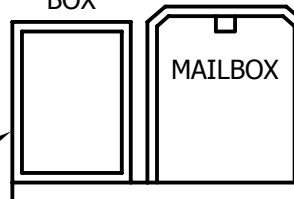

MOUNT AT SAME HEIGHT AS MAILBOX.

FRONT VIEW



**STANDARD DETAILS**

MAILBOX INSTALLATION - URBAN

SPRING LAKE TOWNSHIP

Last Revision:

JAN 2010

Plate No.

GEN-10A

HEIGHT - 48 INCHES  
ABOVE STREET LEVEL

HAVE BOX EXTEND AS  
FAR IN FRONT OF  
SUPPORT POST AS  
POSSIBLE. (THIS  
PREVENTS POSSIBLE  
SNOW PLOW DAMAGE).

ADDRESS MUST BE ON  
SIDE OF BOX FROM  
WHICH CARRIER  
APPROACHES IN  
LETTERS ABOUT ONE  
INCH HIGH. (OR ON  
FRONT WHERE BOXES  
ARE GROUPED).

BOX MUST BE  
LOCATED SO CARRIER  
CAN SERVE WITHOUT  
LEAVING VEHICLE.

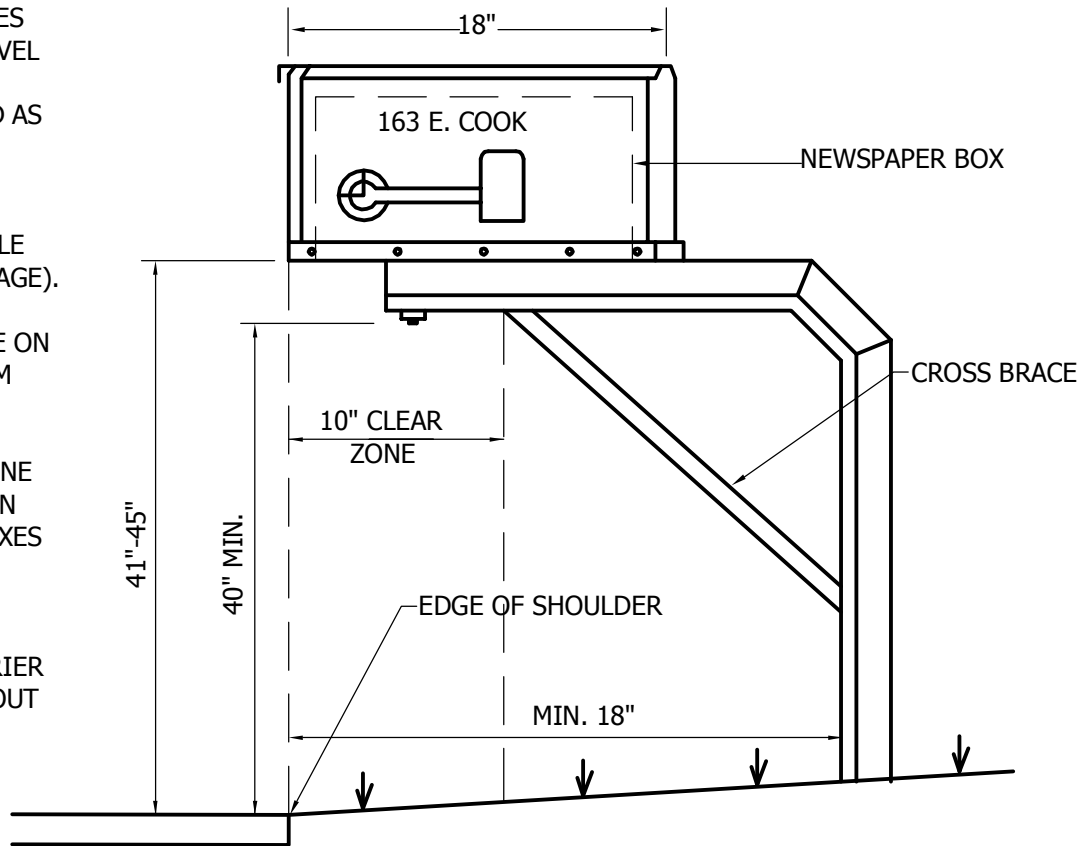

**NOTES:**

MAILBOX SHOULD NOT EXTEND  
BEYOND EDGE OF SHOULDER.

ALL POSTS TO BE A MINIMUM OF 18"  
BEHIND EDGE OF SHOULDER.

DIMENSIONS AS PER U.S. POSTAL  
SERVICE

SIDE VIEW

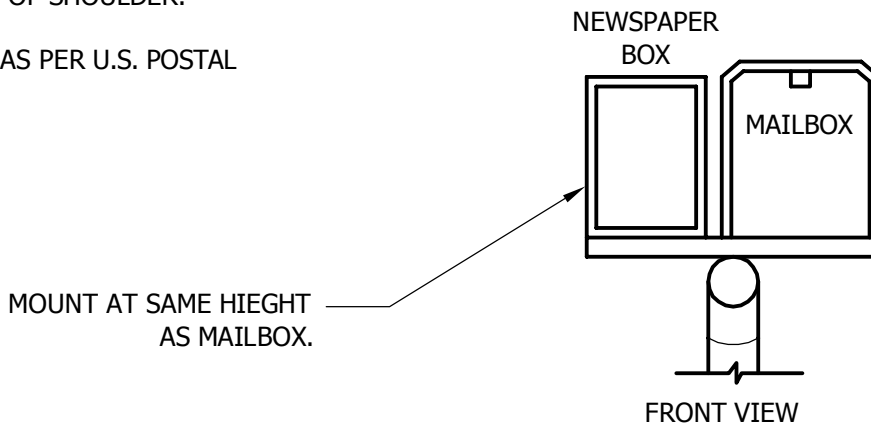

**STANDARD DETAILS**

MAILBOX INSTALLATION - RURAL

SPRING LAKE TOWNSHIP

Last Revision:

JAN 2010

Plate No.

GEN-10B

**PERMANENT CUL-DE-SAC  
PUBLIC STREET - URBAN**

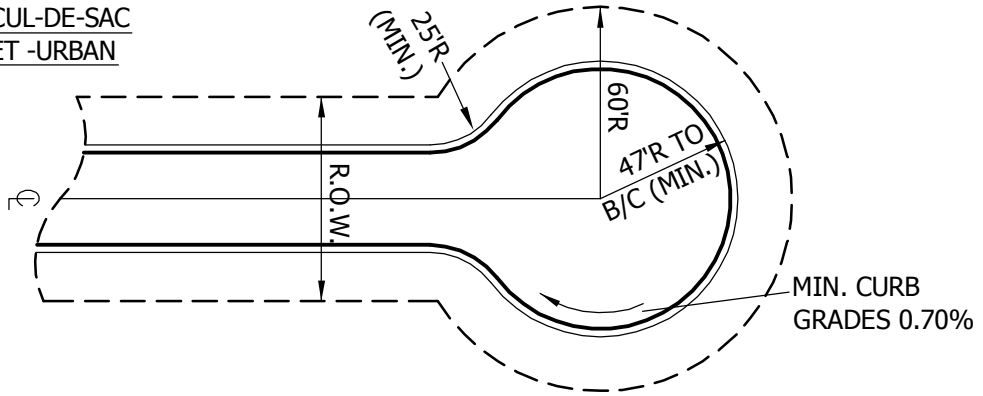

**SURMOUNTABLE  
CURB AND GUTTER**

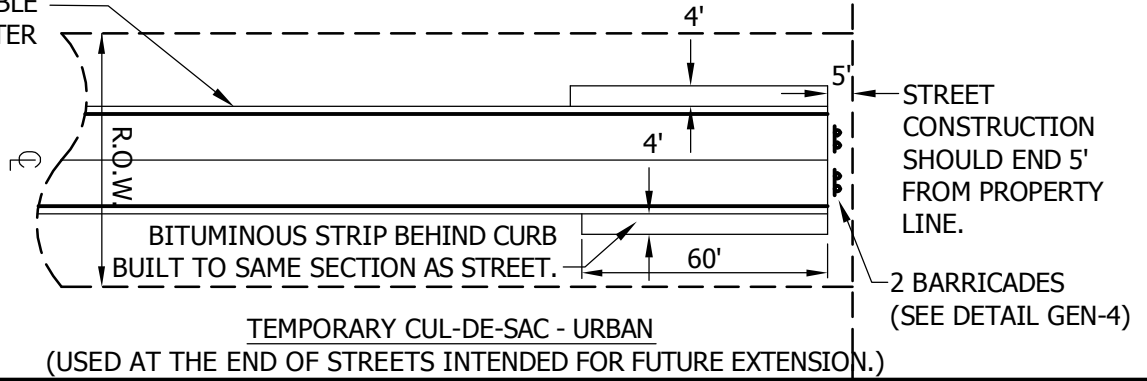

**PERMANENT CUL-DE-SAC  
PUBLIC STREET - RURAL**

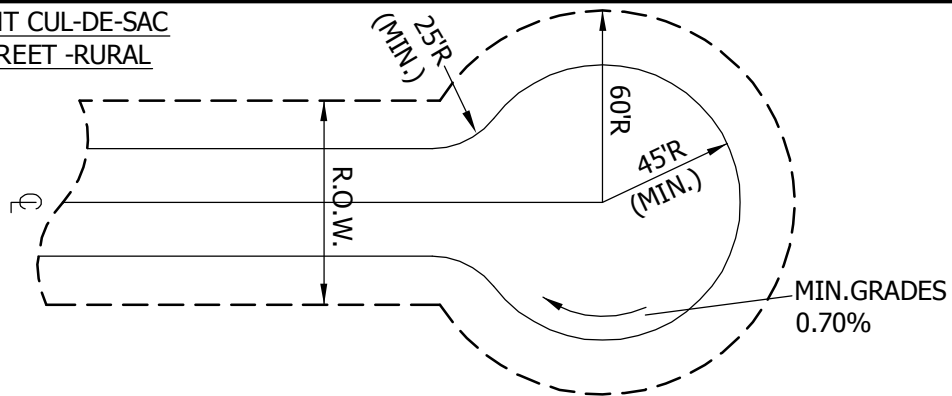

**EDGE OF PAVEMENT**

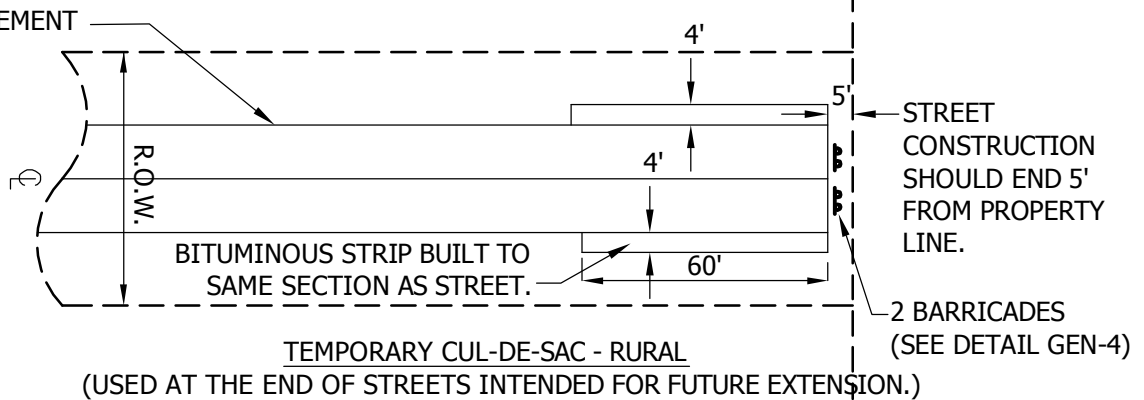

**STANDARD DETAILS  
TYPICAL CUL-DE-SACS**

**SPRING LAKE TOWNSHIP**

Last Revision:

JAN 2010

Plate No.

GEN-11

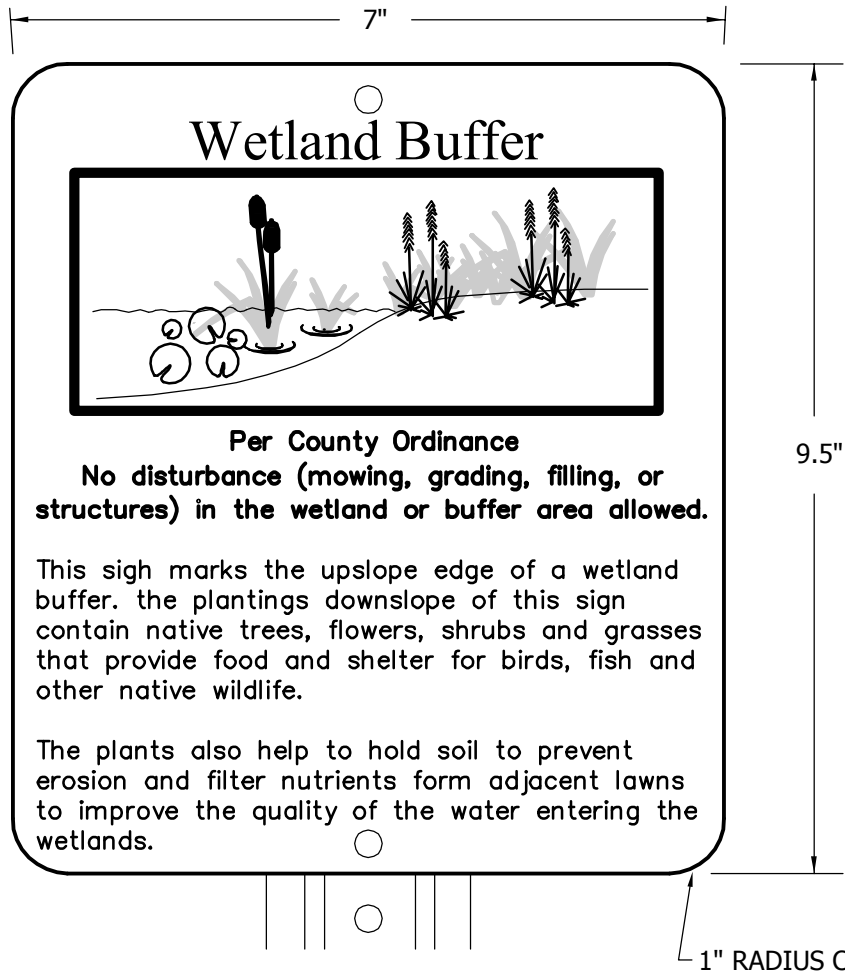

1. THE SIGN MUST BE:
  - A. 0.063 ALUMINUM BLANK,
  - B. BACKGROUND PANTONE: 155 (TAN)
  - C. BLACK VERBIAGE AND LOGO PRINTED ONE SIDE
  - D. PRE DRILL HOLES IN MIDDLE TOP AND BOTTOM (AVOID VERBIAGE)
  - E. TRIM TO BORDER AS SHOWN ON SIGN ARTWORK TO INSURE ROUNDED CORNERS
2. THE MARKER SHALL CONSIST OF A FOUR-INCH SQUARE TREATED OR CEDAR POST OR GREEN STEEL POST INSTALLED TO A HEIGHT OF FOUR FEET ABOVE GRADE AND SET AT LEAST 42 INCHES INTO THE GROUND.
3. BOLT OR SCREW SIGN TO POST
4. ONE SIGN SHALL BE PLACED ON EVERY OTHER COMMON LOT LINE (MIN.), AT ANGLE POINTS AND OTHER APPROPRIATE LOCATIONS AT THE UPSLOPE EDGE OF THE REQUIRED BUFFER STRIP FOR THE WETLAND.  
PROPOSED LOCATIONS OF SIGNS SHALL BE SHOWN ON THE GRADING OR SITE PLAN AND SUBMITTED TO THE TOWNSHIP ENGINEER FOR REVIEW AND APPROVAL.
5. ARTWORK AND VERBIAGE SHALL FACE PROPOSED HOME (STRUCTURE).
6. SOURCE OF SIGN IS AT THE DISCRETION OF THE PROJECT SPONSOR. GRAFFITI SIGN AND DESIGN AT (651) 659-0782 IS A POTENTIAL SOURCE.

1" RADIUS CORNERS



**STANDARD DETAILS**  
WETLAND BUFFER SIGN

SPRING LAKE TOWNSHIP

Last Revision:

JAN 2010

Plate No.

GEN-12

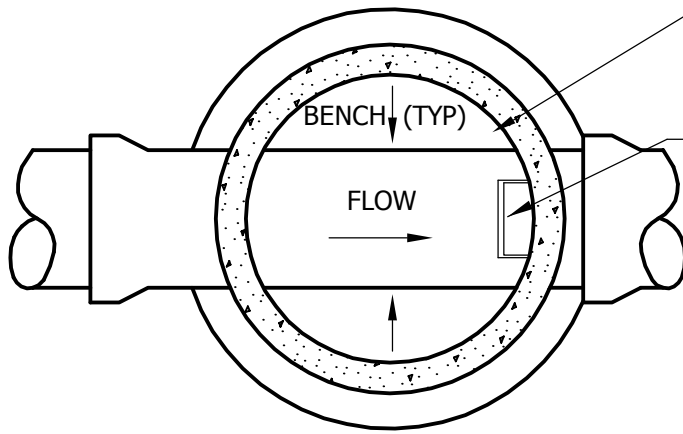

PLAN

GROUT BOTTOM OF MANHOLE TO A MINIMUM OF 1/2 DIAMETER AT PIPE AND SLOPE GROUT 2" TOWARD INVERT.

MANHOLE STEPS SHALL BE PLACED SO THAT OFFSET VERTICAL PORTION OF CONE IS FACING DOWNSTREAM FOR ALL PIPES UP TO 24". PLACE STEPS ON RIGHT HAND SIDE WHEN FACING DOWN STREAM FOR ALL PIPES 24" AND OVER.

APPROVED CASTINGS

CASTING	A	B
NEENAH R1642B	27"	7"
MCI 309	27"	7"

ONE PIECE STEEL ADJUSTING RING AS DISTRIBUTED BY ESS. BROS. INC., MAY BE USED IN LIEU OF CONVENTIONAL ADJUSTMENT.

NEENAH FRAME AND COVER OR EQUAL LETTERED, "STORM SEWER", WITH 2 CONCEALED PICK HOLES.

POUR CONCRETE COLLAR AROUND EXTERIOR OF RINGS.

MINIMUM OF 2 MAXIMUM OF 5 CONCRETE ADJUSTMENT RINGS WITH FULL BED OF MORTAR BETWEEN EACH RING.

MAXIMUM 20" ADJUSTMENT ALLOWED INCLUDING RINGS AND CASTING.

MANHOLE STEPS, COPOLYMER POLYPROPYLENE PLASTIC, WITH 1/2" GRADE 60 STEEL REINFORCEMENT OR EQUAL, 16" ON CENTER. (NO STEPS ALLOWED IN UPPER 27" BARREL.)

ALL JOINTS IN MANHOLE TO HAVE "O" RING RUBBER GASKETS.

\*\*DOG HOUSES MUST BE GROUTED BOTH INSIDE AND OUTSIDE OF STRUCTURE.

PIPE SHALL BE CUT OUT 2" FROM INSIDE FACE OF WALL.

MINIMUM SLAB THICKNESS, 6" TO 14' DEPTH. INCREASE THICKNESS 1" FOR EACH 4' OF DEPTH GREATER THAN 14', AND REINFORCE WITH 6"X6" 10/10 MESH.

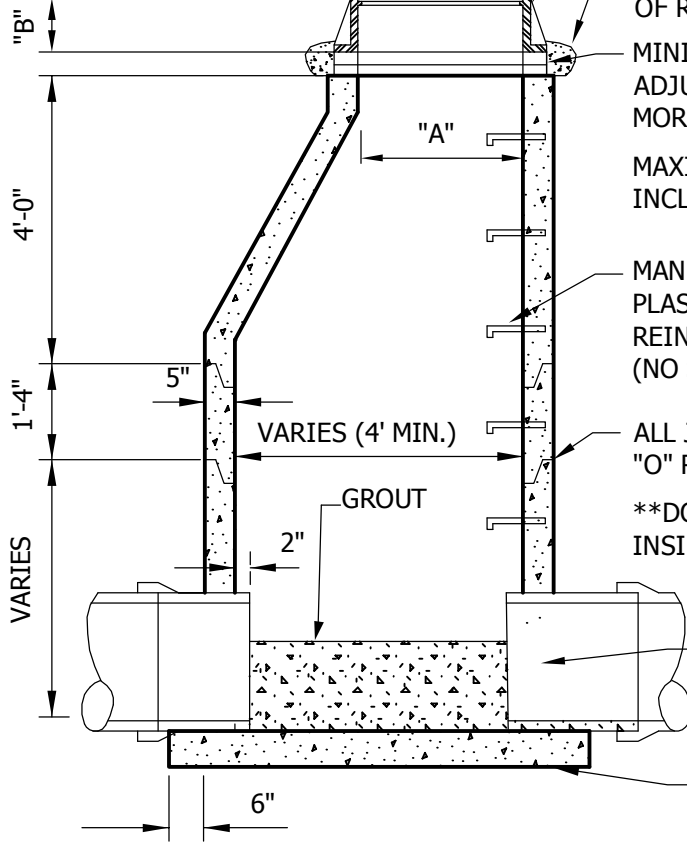

SECTION



**STANDARD DETAILS**  
STORM SEWER MANHOLE

SPRING LAKE TOWNSHIP

Last Revision:

JAN 2010

Plate No.

STO-1

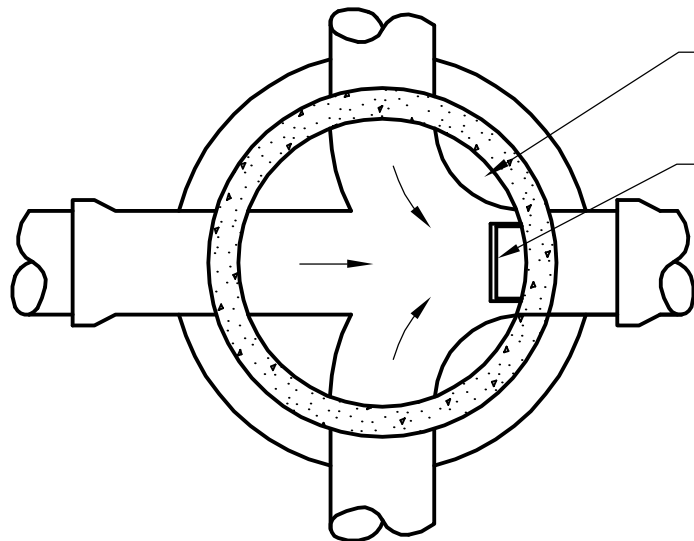

GROUT BOTTOM OF MANHOLE TO A MINIMUM OF 1/2 DIAMETER AT PIPE AND SLOPE GROUT 2" TOWARD INVERT.

MANHOLE STEPS SHALL BE PLACED SO THAT OFFSET VERTICAL PORTION OF CONE IS FACING DOWNSTREAM FOR ALL PIPES UP TO 24". PLACE STEPS ON RIGHT HAND SIDE WHEN FACING DOWN STREAM FOR ALL PIPES 24" AND OVER.

APPROVED CASTINGS

CASTING	A	B
NEENAH R1642B	27"	7"
MCI	27"	7"

PLAN

ONE PIECE STEEL ADJUSTING RING AS DISTRIBUTED BY ESS. BROS. INC., MAY BE USED IN LIEU OF CONVENTIONAL ADJUSTMENT.

NEENAH FRAME AND COVER OR EQUAL LETTERED, "STORM SEWER", WITH 2 CONCEALED PICK HOLES.

POUR CONCRETE COLLAR AROUND EXTERIOR OF RINGS.

MINIMUM OF 2 MAXIMUM OF 4 CONCRETE ADJUSTMENT RINGS WITH FULL BED OF MORTAR BETWEEN EACH RING.

MAXIMUM 20" ADJUSTMENT ALLOWED INCLUDING RINGS AND CASTING.

MANHOLE STEPS, COPOLYMER POLYPROPYLENE PLASTIC, WITH 1/2" GRADE 60 STEEL REINFORCEMENT OR EQUAL, 16" ON CENTER. (NO STEPS ALLOWED IN UPPER 27" BARREL.)

ALL JOINTS IN MANHOLE TO HAVE "O" RING RUBBER GASKETS.

\*\*DOG HOUSES MUST BE GROUTED BOTH INSIDE AND OUTSIDE OF STRUCTURE.

PIPE SHALL BE CUT OUT 2" FROM INSIDE FACE OF WALL.

MINIMUM SLAB THICKNESS, 6" FOR 14' DEPTH. INCREASE THICKNESS 1" FOR EACH 4' OF DEPTH GREATER THAN 14', AND REINFORCE WITH 6"X6" 10/10 MESH.

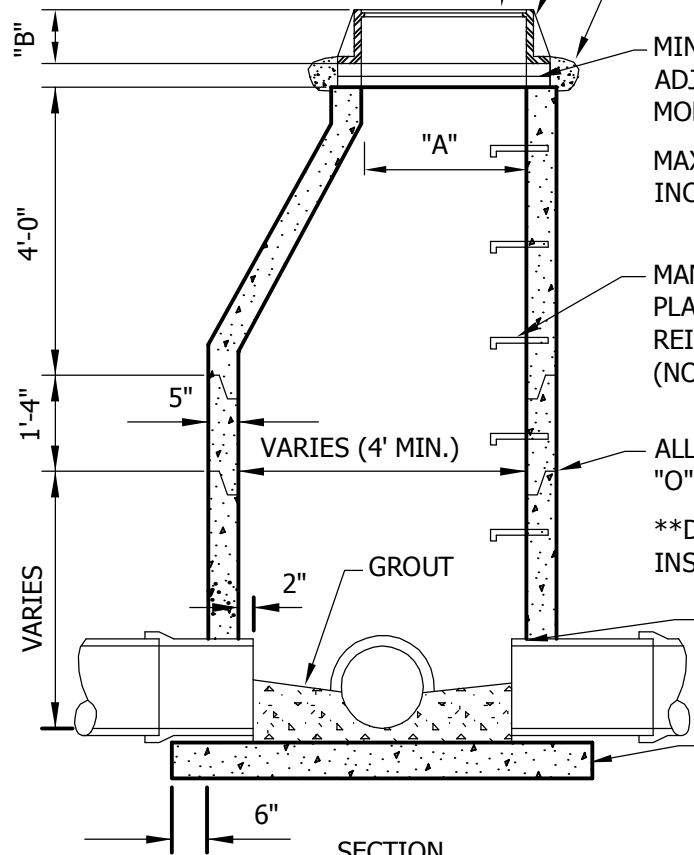

SECTION



**STANDARD DETAILS**

STORM SEWER JUNCTION MANHOLE

SPRING LAKE TOWNSHIP

Last Revision:

JAN 2010

Plate No.

STO-2

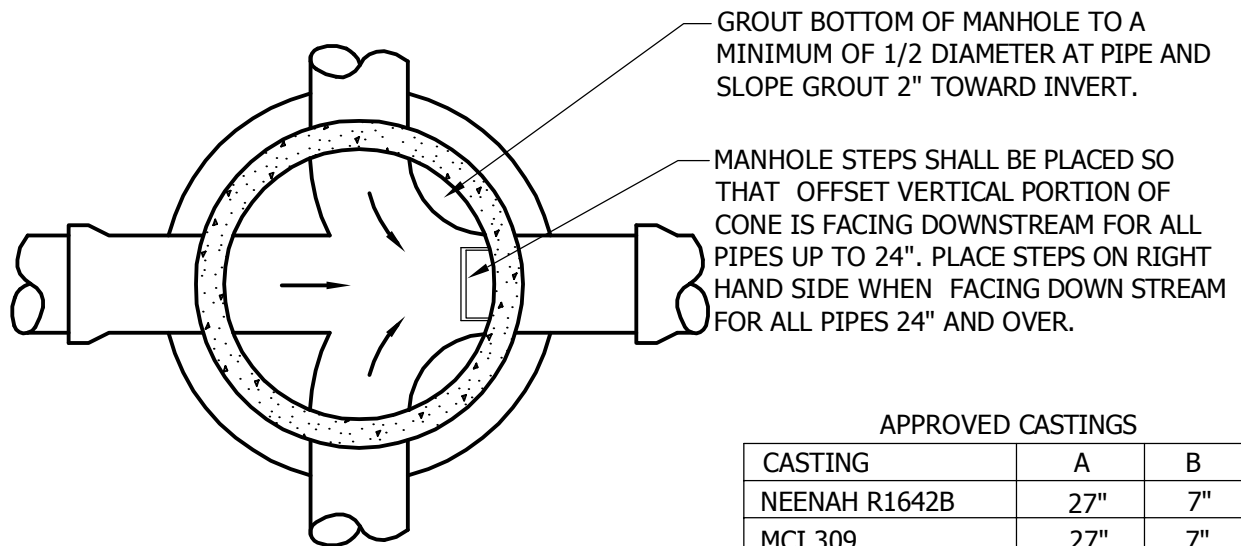

PLAN

APPROVED CASTINGS

CASTING	A	B
NEENAH R1642B	27"	7"
MCI 309	27"	7"

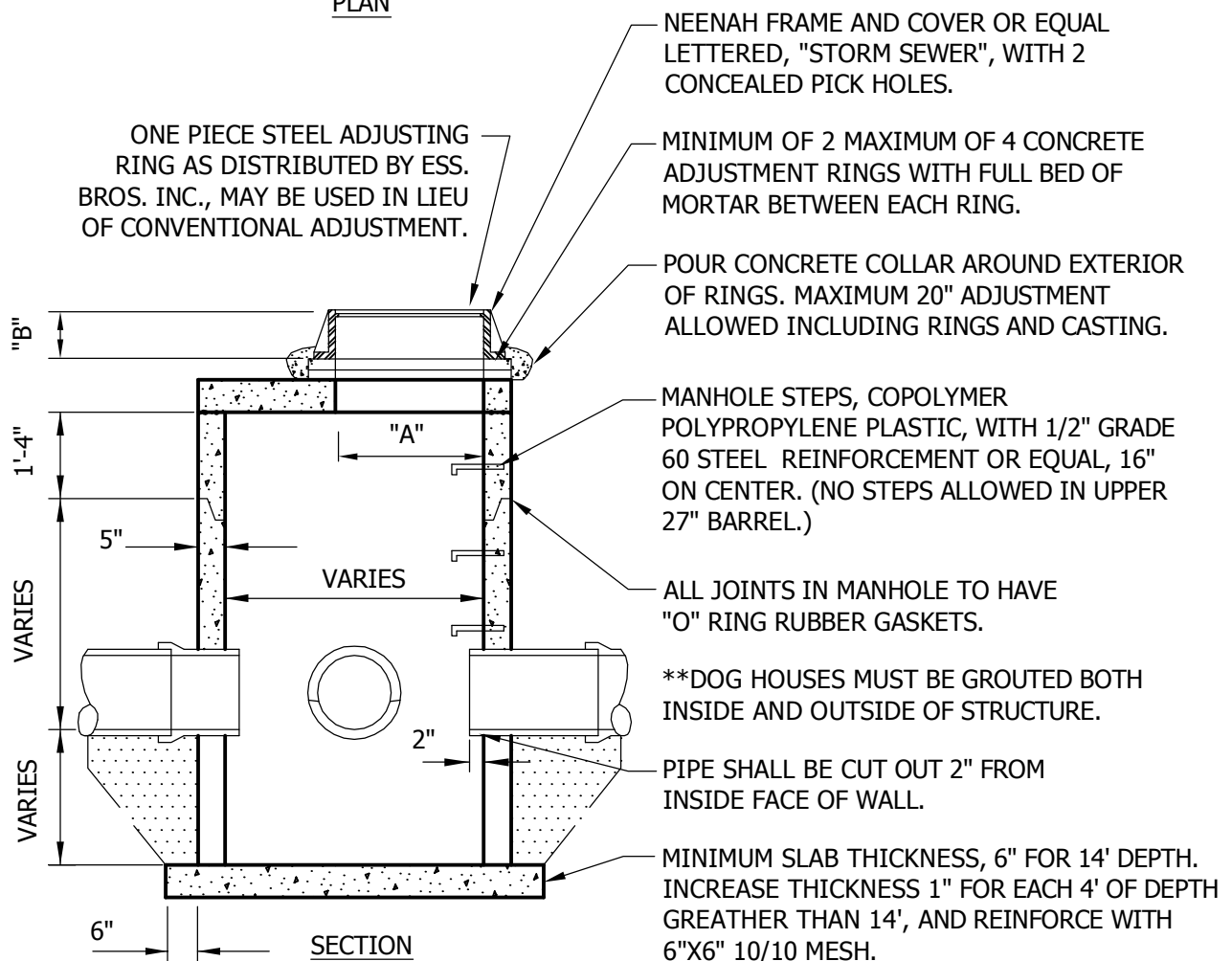

SECTION



**STANDARD DETAILS**  
 STORM SEWER JUNCTION MANHOLE  
 WITH REINFORCED TOP SLAB & SUMP

**SPRING LAKE TOWNSHIP**

Last Revision:

JAN 2010

Plate No.

STO-3

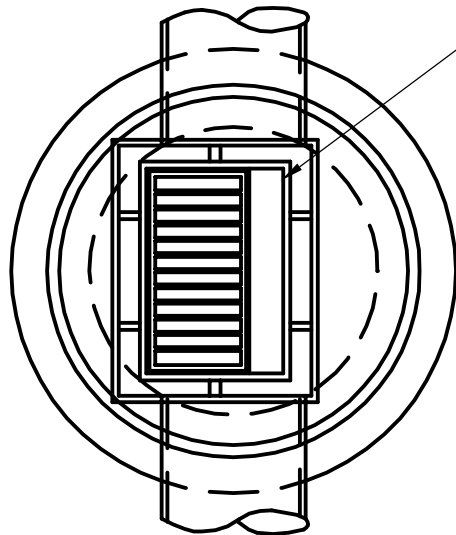

PLAN

24"X36" SLAB OPENING FOR NEENAH R3067V OR ESS. BROS. 330 HIGH CAPACITY OR EQUAL. INSTALL R3290L FOR DRIVEWAYS AND VALLEY GUTTERS. (VANE GRATE SHOWN)

DIMENSION FROM BACK OF CURB TO CENTER OF PIPE:  
 4' DIA. MH - 9" IN FROM BACK OF CURB  
 5' DIA. MH - 3" IN FROM BACK OF CURB  
 6' DIA. MH - 3" BEHIND BACK OF CURB  
 7' DIA. MH - 9" BEHIND BACK OF CURB  
 8' DIA. MH - 15" BEHIND BACK OF CURB

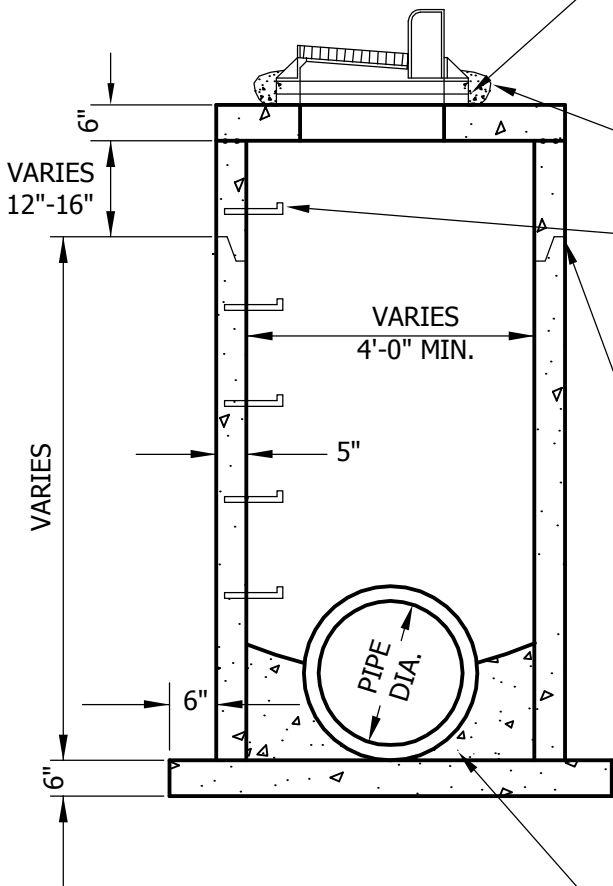

SECTION

MINIMUM OF 2 MAXIMUM OF 5 CONCRETE ADJUSTMENT RINGS WITH FULL BED OF MORTAR BETWEEN EACH RING.

MAXIMUM 20" ADJUSTMENT ALLOWED INCLUDING RINGS AND CASTING.

POUR CONCRETE COLLAR AROUND EXTERIOR OF RINGS.

MANHOLE STEPS, COPOLYMER POLYPROPYLENE PLASTIC, WITH 1/2" GRADE 60 STEEL REINFORCEMENT OR EQUAL, 16" ON CENTER. (NO STEPS ALLOWED IN UPPER 27" BARREL.)

ALL JOINTS IN MANHOLE TO HAVE "O" RING RUBBER GASKETS.

\*\*DOG HOUSES MUST BE GROUTED BOTH INSIDE AND OUTSIDE OF STRUCTURE.

PIPE SHALL BE CUT OUT 2" FROM INSIDE FACE OF WALL.

MINIMUM SLAB THICKNESS, 6" FOR 14' DEPTH. INCREASE THICKNESS 1" FOR EACH 4' OF DEPTH GREATER THAN 14', AND REINFORCE WITH 6"X6" 10/10 MESH.

GROUT BOTTOM



**STANDARD DETAILS**  
 CATCH BASIN MANHOLE

**SPRING LAKE TOWNSHIP**

Last Revision:

JAN 2010

Plate No.

STO-4



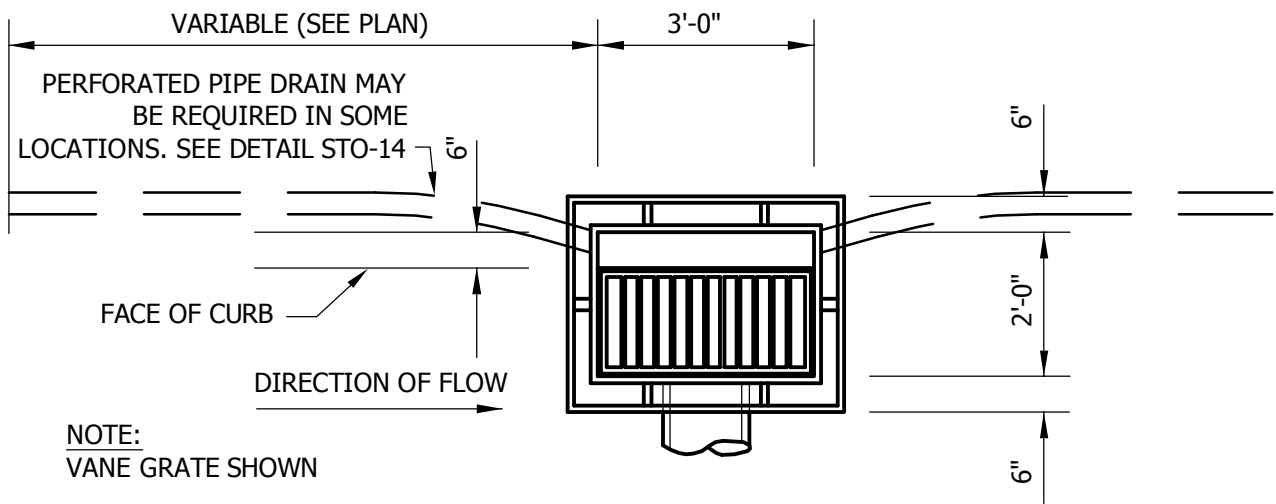

PLAN

CATCHBASIN CASTING NEENAH R3067V OR ESS.BRO.330 HIGH CAPACITY OR EQUAL WITH VANE GRATE 3" RADIUS CURB BOX. INSTALL R3290L CASTING IN DRIVEWAYS AND VALLEY GUTTERS.

GRATE TO BE 2" BELOW GUTTER GRADE. 10' TRANSITION EACH SIDE OF CATCH BASIN.

MIN. OF 2 MAX. OF 5 CONCRETE ADJUSTMENT RINGS WITH FULL BED OF GROUT BETWEEN EACH RING.

MAXIMUM 20" ADJUSTMENT ALLOWED INCLUDING RINGS AND CASTING.

DOGHOUSES SHALL BE GROUTED ON BOTH THE OUTSIDE AND THE INSIDE.

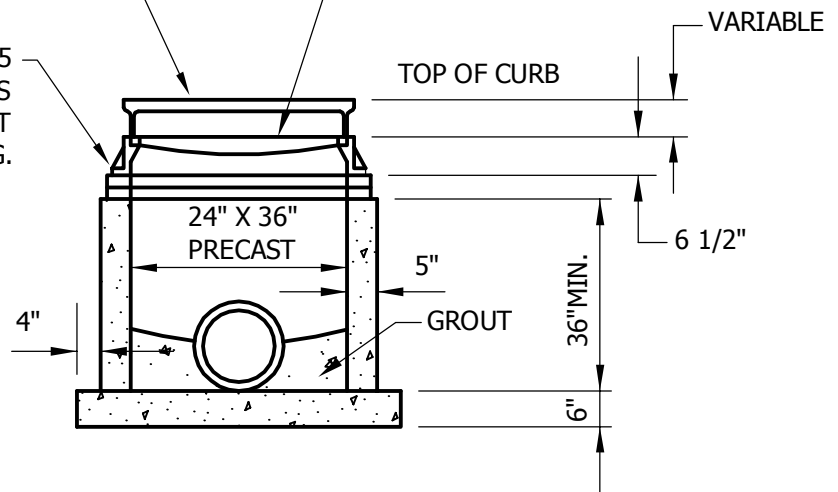

SECTION



**STANDARD DETAILS**  
2'x3' CATCH BASIN

Last Revision:

JAN 2010

Plate No.

STO-5

SPRING LAKE TOWNSHIP

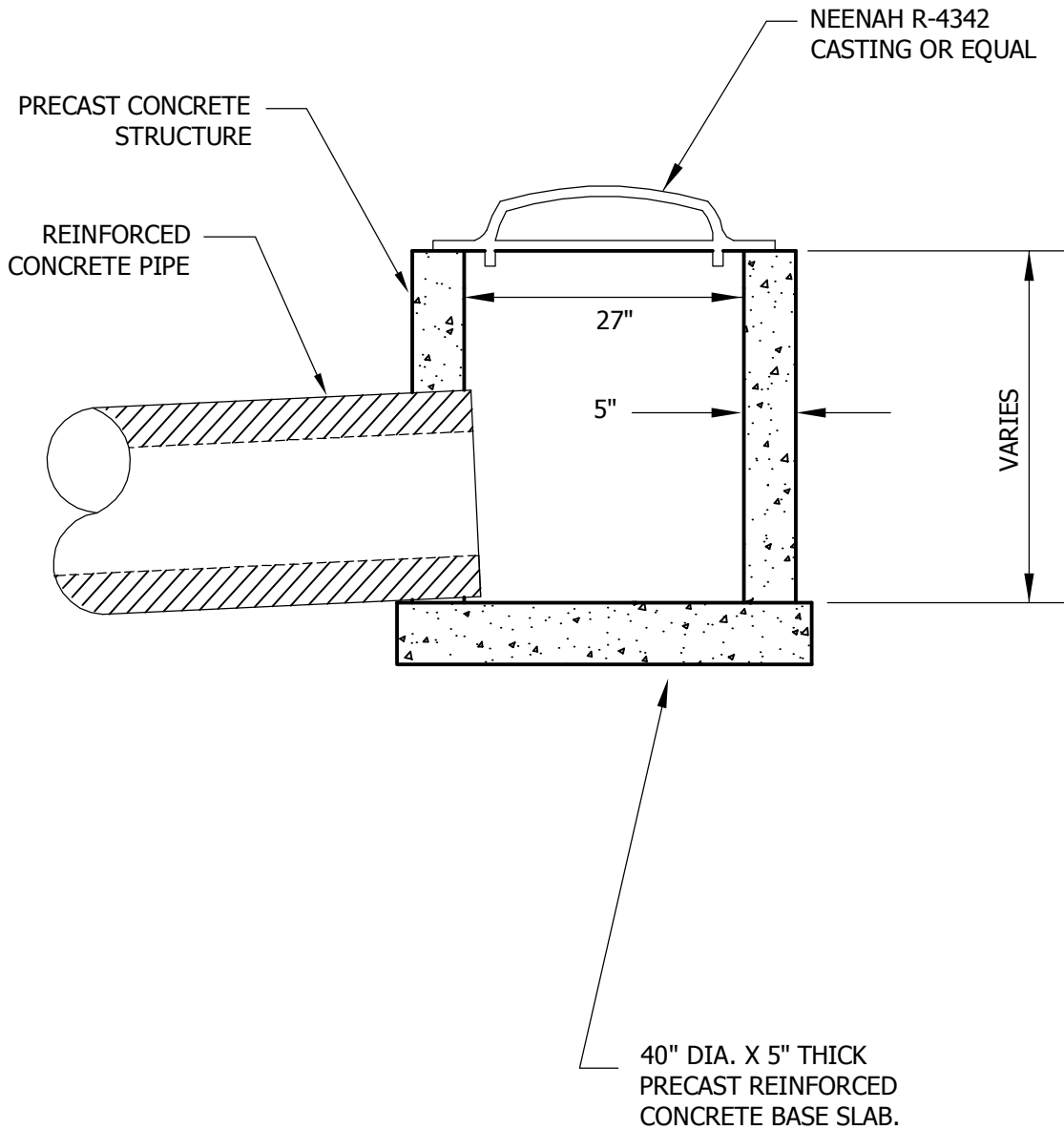

**STANDARD DETAILS**  
 PRECAST 27" DIAMETER  
 SHALLOW DEPTH CATCH BASIN  
 SPRING LAKE TOWNSHIP

Last Revision:

JAN 2010

Plate No.

STO-6

NOTE: TRASH GUARDS TO BE USED AT INLETS ONLY.

SEE PLATE NO. STO-8 FOR RIPRAP PLACEMENT.

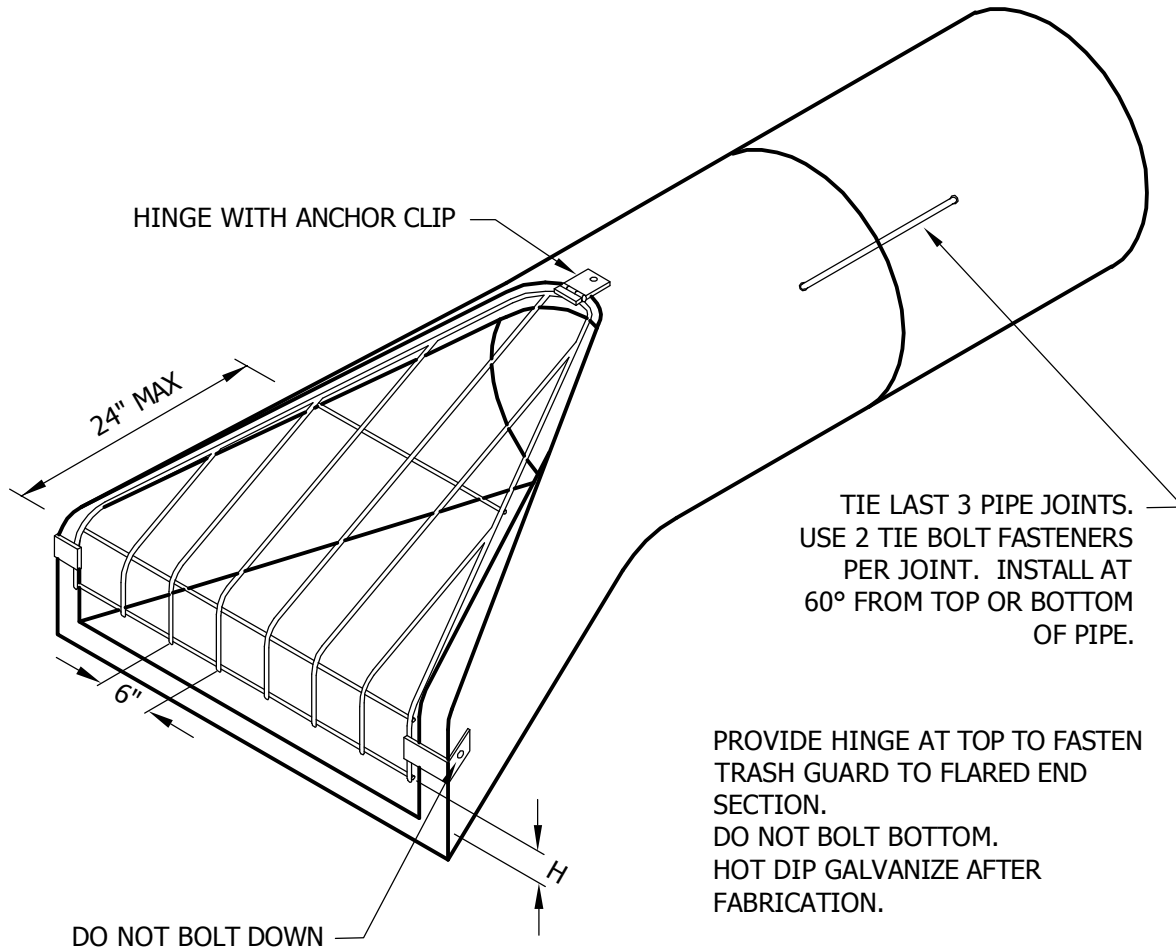

PROVIDE HINGE AT TOP TO FASTEN TRASH GUARD TO FLARED END SECTION.  
DO NOT BOLT BOTTOM.  
HOT DIP GALVANIZE AFTER FABRICATION.

TRASH GUARD SIZING

PIPE SIZE	BARS	H	BOLTS
12"	3/4"Ø	2 1/2"	5/8"
15"	3/4"Ø	3"	5/8"
18"	3/4"Ø	4"	5/8"
21"-24"	1"Ø	4"	3/4"
27"-36"	1"Ø	5"	3/4"
42"	1"Ø	6"	3/4"
48"-54"	1 1/4"Ø	6"	1"
60"-72"	1 1/4"Ø	7"	1"
78"-90"	1 1/4"Ø	8"	1"



**STANDARD DETAILS**  
FLARED END SECTION  
AND TRASH GUARD

**SPRING LAKE TOWNSHIP**

Last Revision:

JAN 2010

Plate No.

STO-7

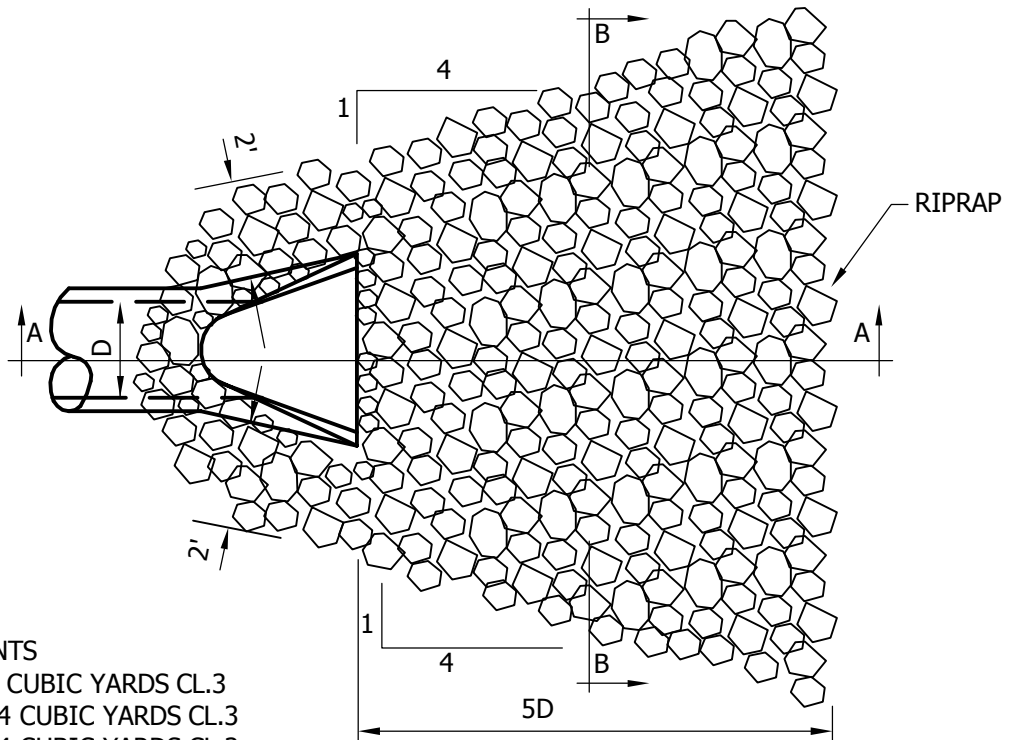

**RIPRAP REQUIREMENTS**

12" TO 18"	8-10 CUBIC YARDS CL.3
21" TO 27"	12-14 CUBIC YARDS CL.3
30" TO 36"	16-24 CUBIC YARDS CL.3
42" TO 48"	30-38 CUBIC YARDS CL.3
54" AND UP	62 & UP CUBIC YARDS CL.4

**PLAN**

(ONE CUBIC YARD IS APPROXIMATELY 2,800 LBS.)

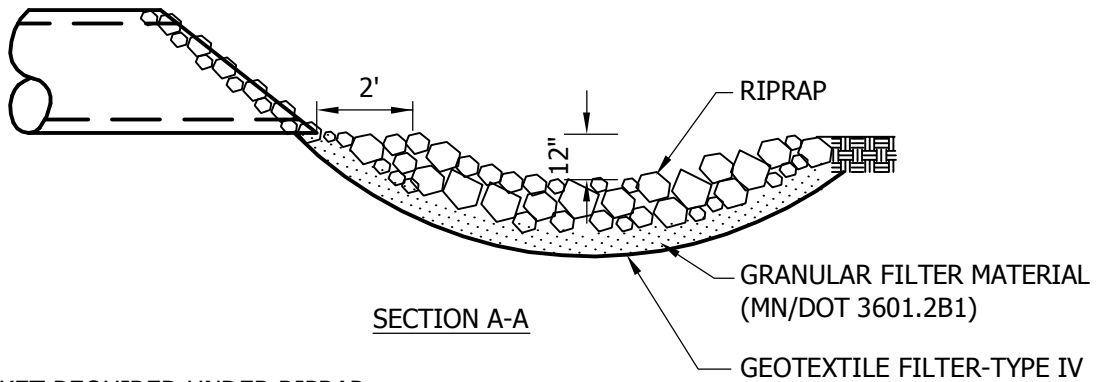

**SECTION A-A**

**NOTE**  
 FILTER BLANKET REQUIRED UNDER RIPRAP  
 OR 2 LAYERS OF 500X MIRAFLI FABRIC OR  
 EQUAL

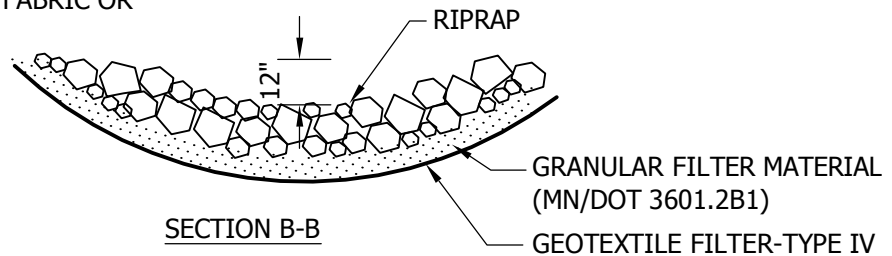

**SECTION B-B**



**STANDARD DETAILS**  
**RIPRAP AT OUTLETS**

Last Revision:

JAN 2010

Plate No.

STO-8

**SPRING LAKE TOWNSHIP**

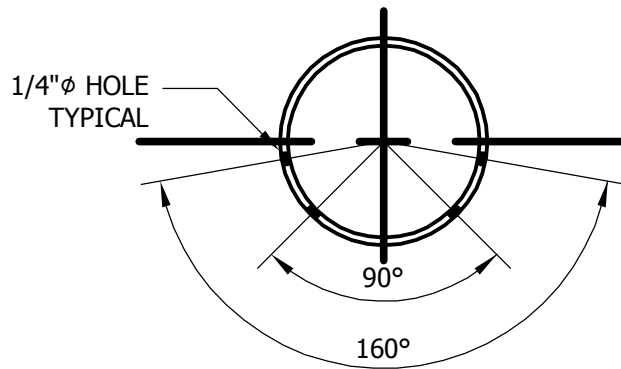
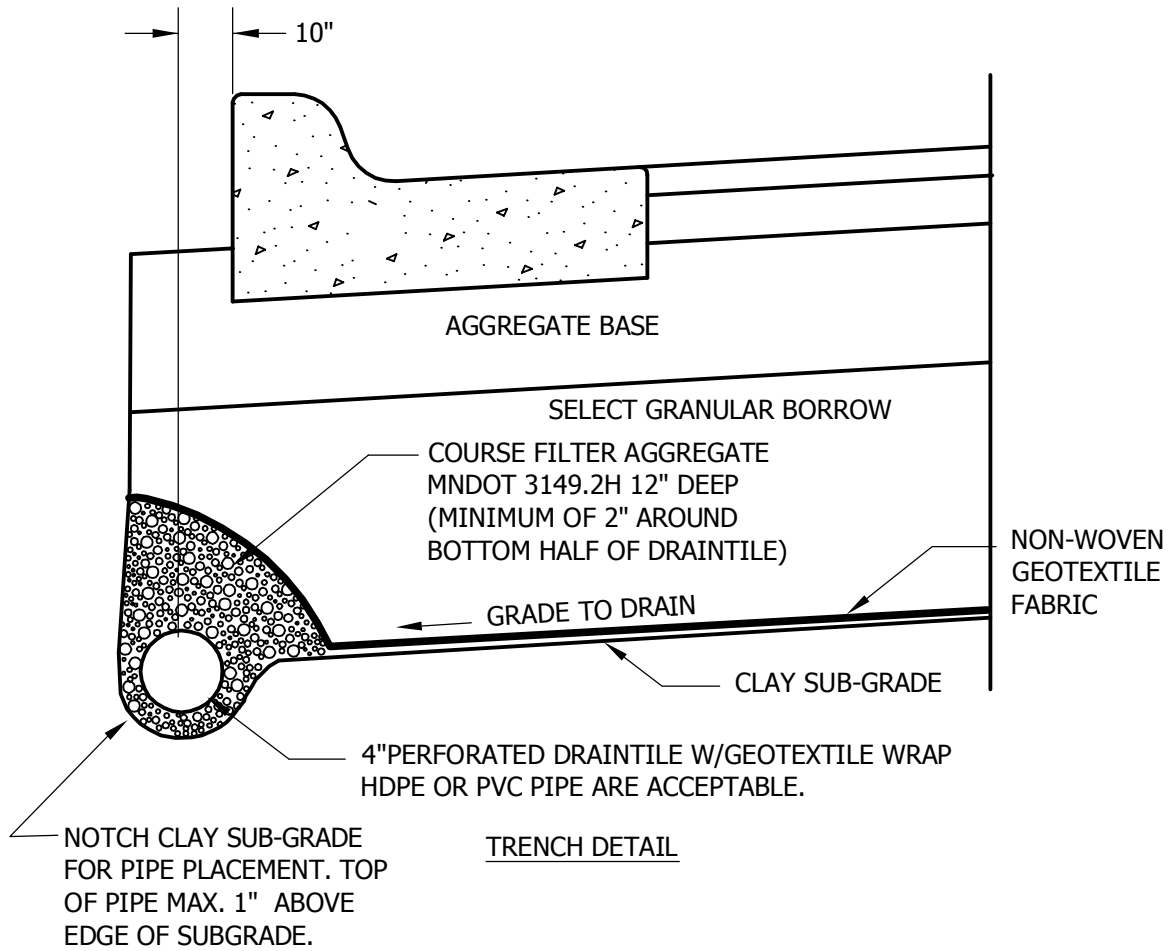

**STANDARD DETAILS**  
PERFORATED DRAINTILE PIPE  
BELOW CONCRETE CURB

**SPRING LAKE TOWNSHIP**

Last Revision:

JAN 2010

Plate No.

STO-9

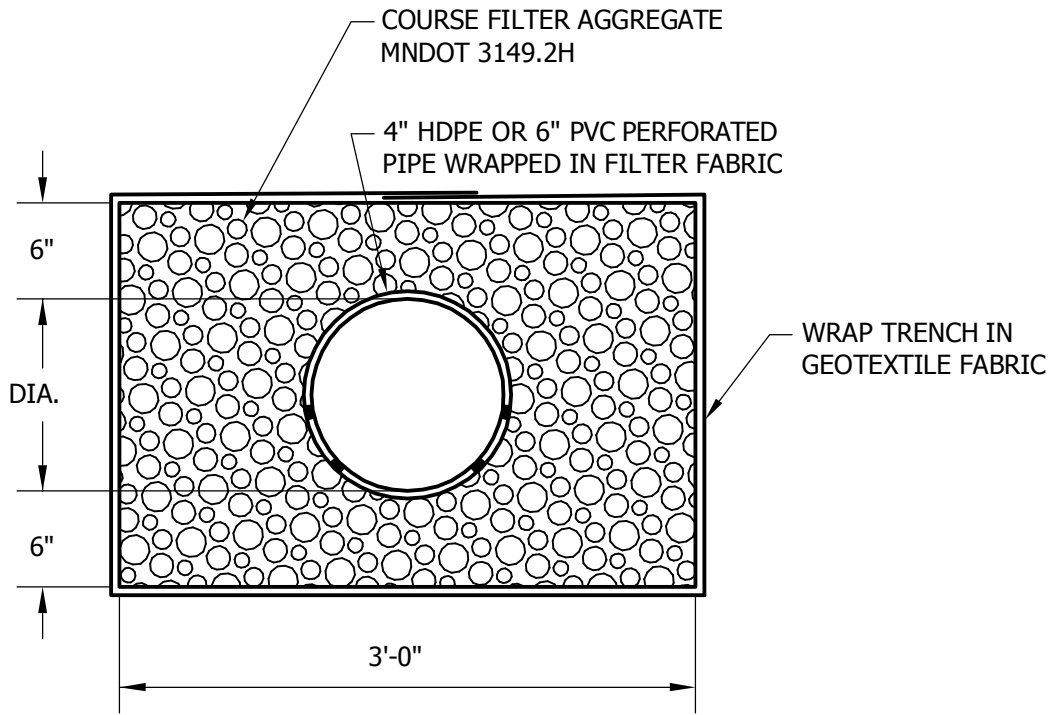

TRENCH DETAIL

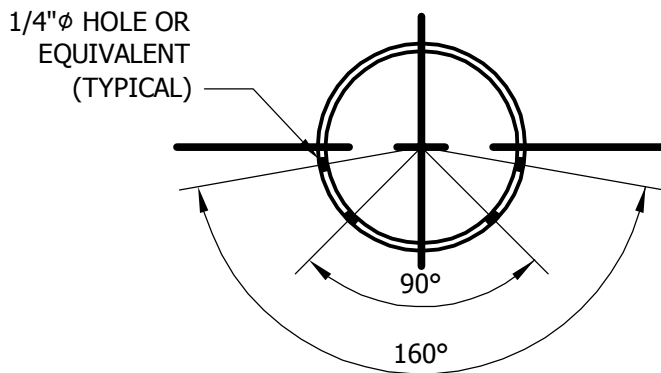

PIPE DETAIL



**STANDARD DETAILS**  
 PERFORATED DRAINTILE PIPE  
 TRENCH DETAIL

**SPRING LAKE TOWNSHIP**

Last Revision:  
 JAN 2010

Plate No.  
 STO-10

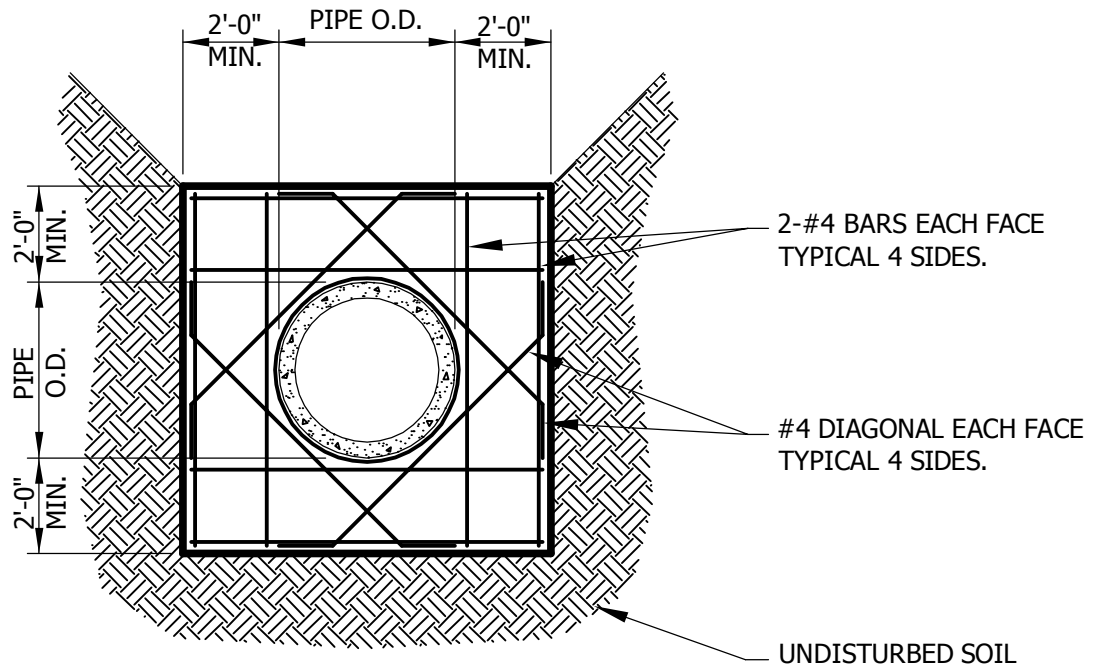

SECTION AA

NOTE:  
NO BLOCK OR OTHER  
FILLER ALLOWED

NOTE:  
NOTCH ALL SIDES INTO  
UNDISTURBED SOIL

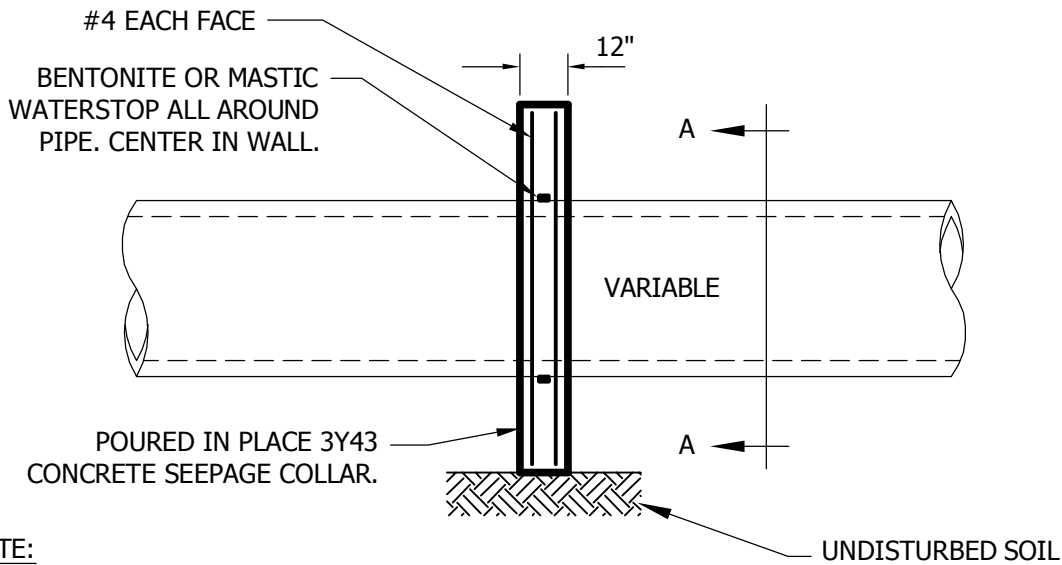

NOTE:  
COLLAR MUST BE  
ADEQUATELY FRAMED  
USING WOOD OR OTHER  
ACCEPLABLE MATERIAL



**STANDARD DETAILS**  
SEEPAGE COLLAR

Last Revision:

JAN 2010

Plate No.

STO-11

SPRING LAKE TOWNSHIP

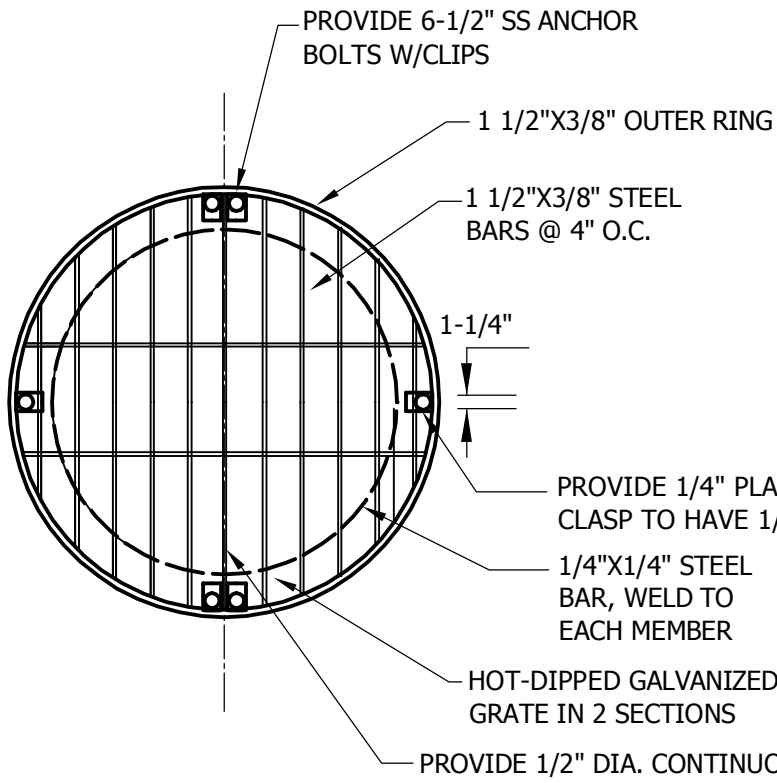

MH DIAMETER	SKIMMER OPENING
4'	3'X1.5'
5'	5'X1.5'
6'	6'X1.5'

GRATE DETAIL

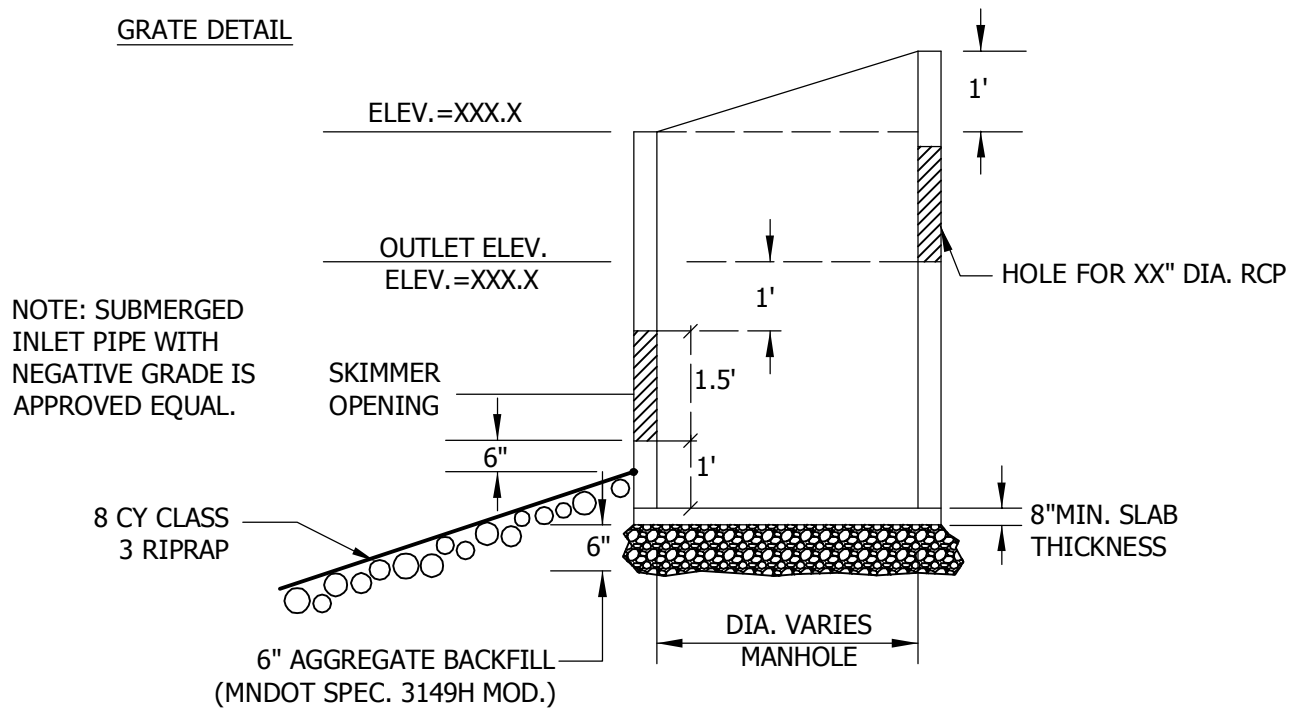

**STANDARD DETAILS**  
STANDARD SKIMMER STRUCTURE

**SPRING LAKE TOWNSHIP**

Last Revision:  
JAN 2010

Plate No.  
ST0-12



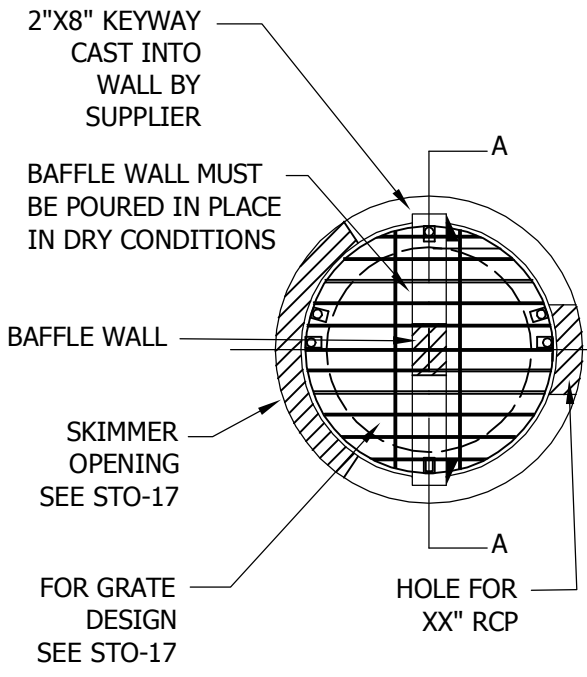

**SKIMMER GRATE**

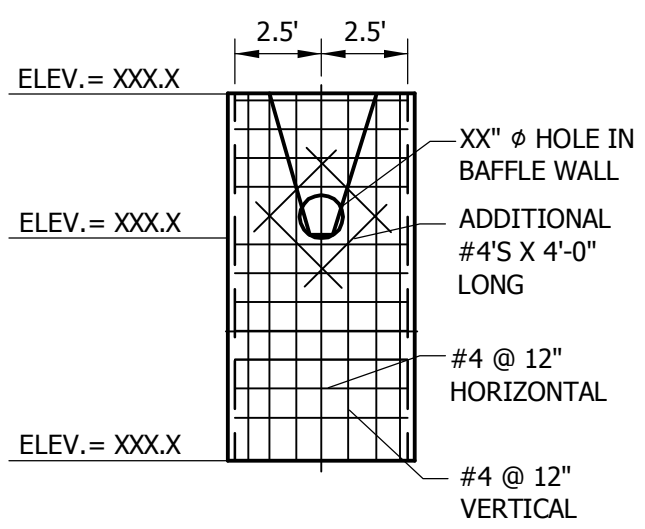

**SECTION A-A  
CONCRETE BAFFLE WALL**

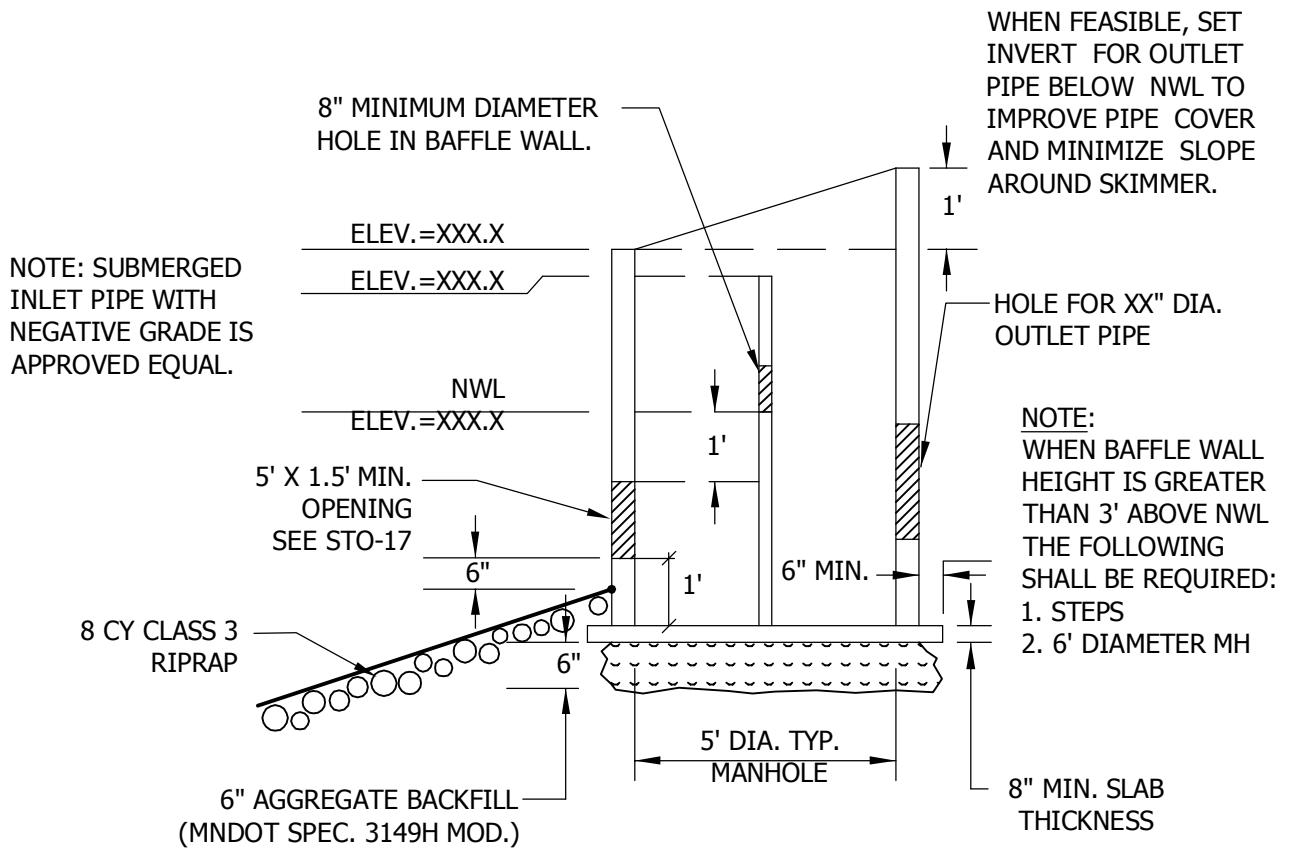

**STANDARD DETAILS**  
SKIMMER STRUCTURE  
WITH CONCRETE BAFFLE WALL  
**SPRING LAKE TOWNSHIP**

Last Revision:  
**JAN 2010**

Plate No.  
**STO-13**

\* MAINTENANCE BENCH ALSO  
REQUIRED AT FESS.

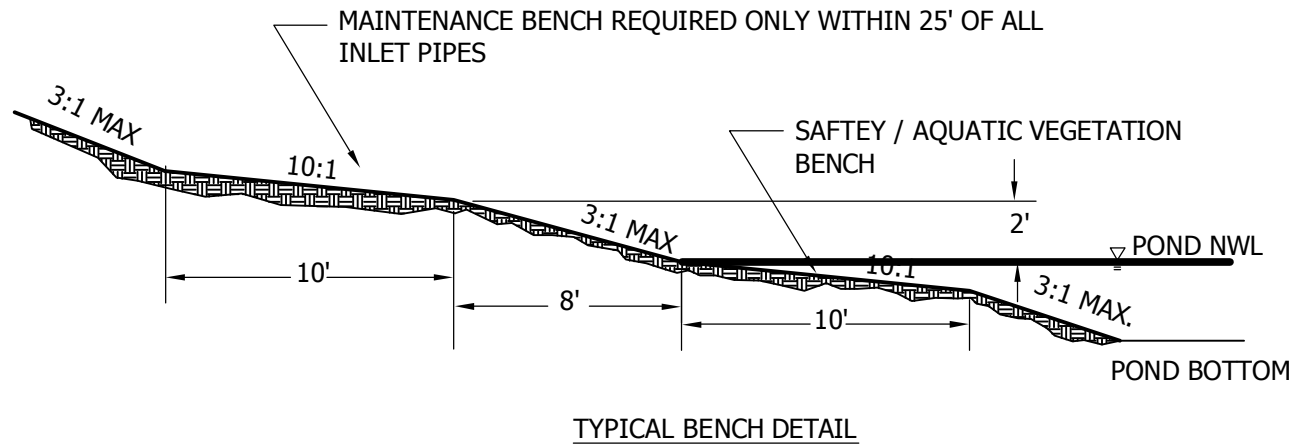
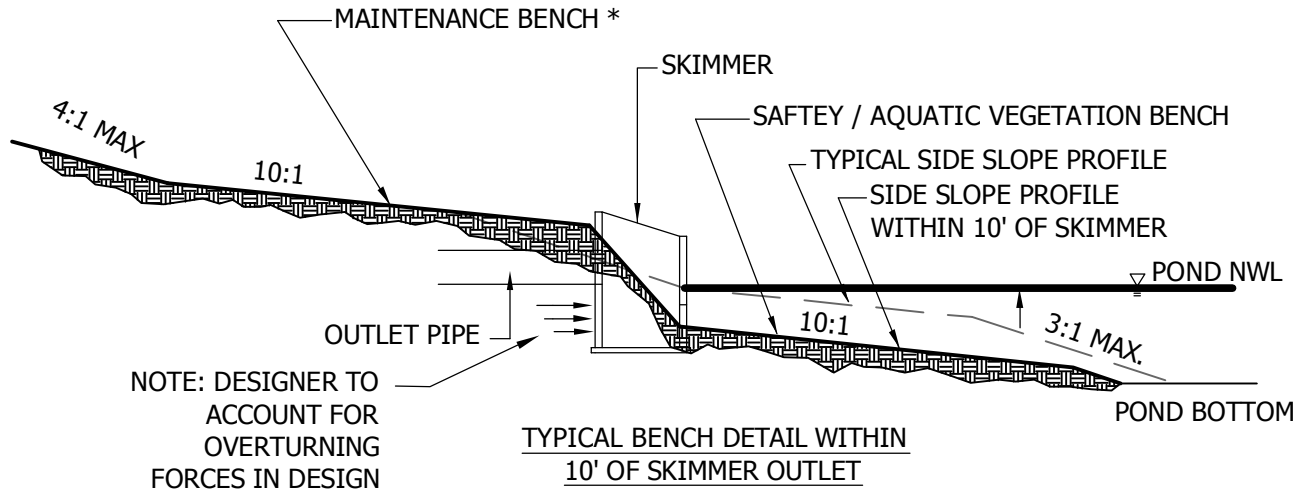

**STANDARD DETAILS**  
TYPICAL POND BENCH DETAIL

SPRING LAKE TOWNSHIP

Last Revision:

JAN 2010

Plate No.

STO-14

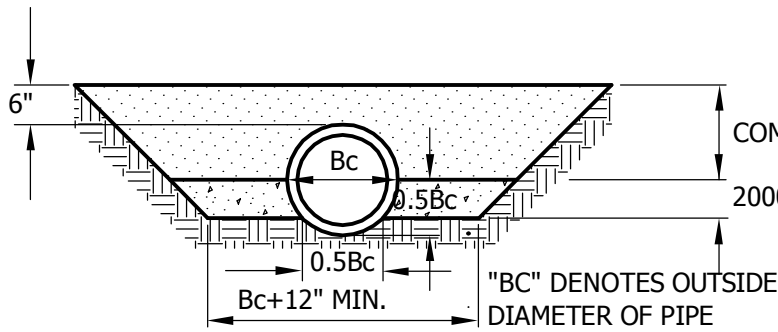

COMPACTED BACKFILL

2000# CONCRETE

LOAD FACTOR 2.3

CLASS A

CONCRETE BACKFILL TO 0.5 OF OUTSIDE DIAMETER WITH SHAPED BEDDING.

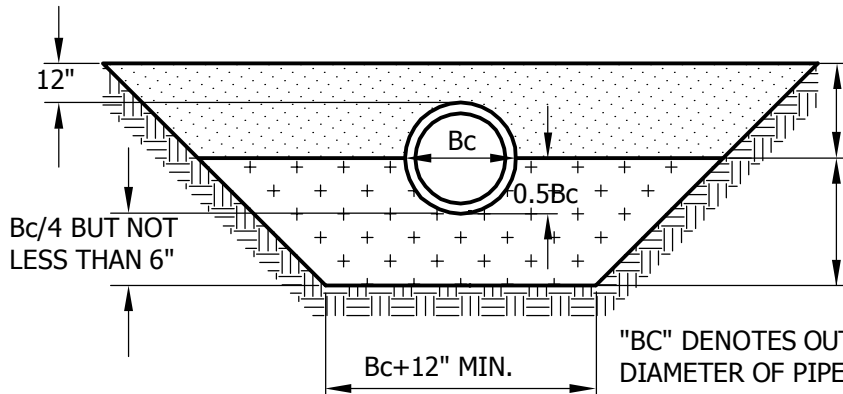

COMPACTED BACKFILL

COURSE FILTER AGGREGATE  
MNDOT SPEC. 3149H MOD.

LOAD FACTOR 1.9

CLASS B

HAND SHAPED FROM ANGULAR BEDDING MATERIAL

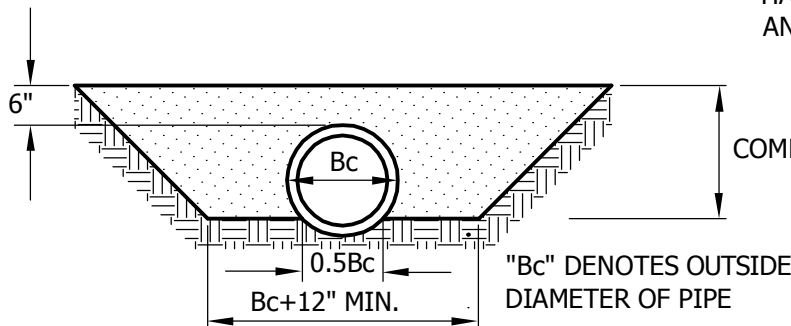

COMPACTED BACKFILL

LOAD FACTOR 1.5

CLASS C-1

HAND SHAPED FROM FIRM UNDISTURBED SOIL

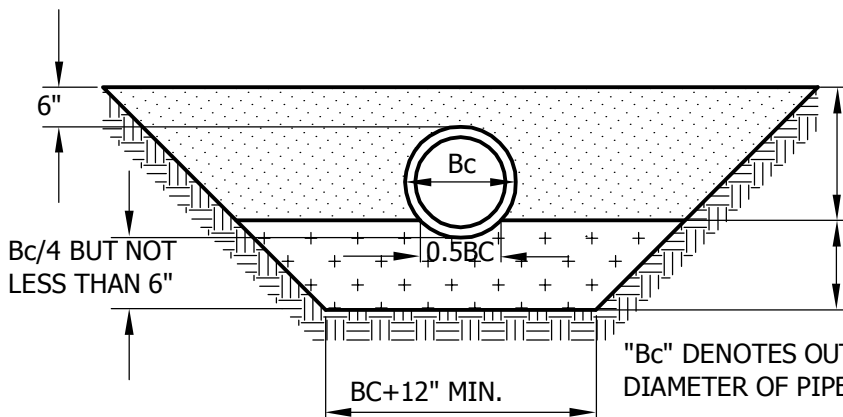

COMPACTED BACKFILL

COURSE FILTER AGGREGATE  
MNDOT SPEC. 3149H MOD.

LOAD FACTOR 1.5

CLASS C-2

HAND SHAPED FROM ANGULAR BEDDING MATERIAL



**STANDARD DETAILS**  
BEDDING METHODS FOR RCP

**SPRING LAKE TOWNSHIP**

Last Revision:

JAN 2010

Plate No.

STO-15

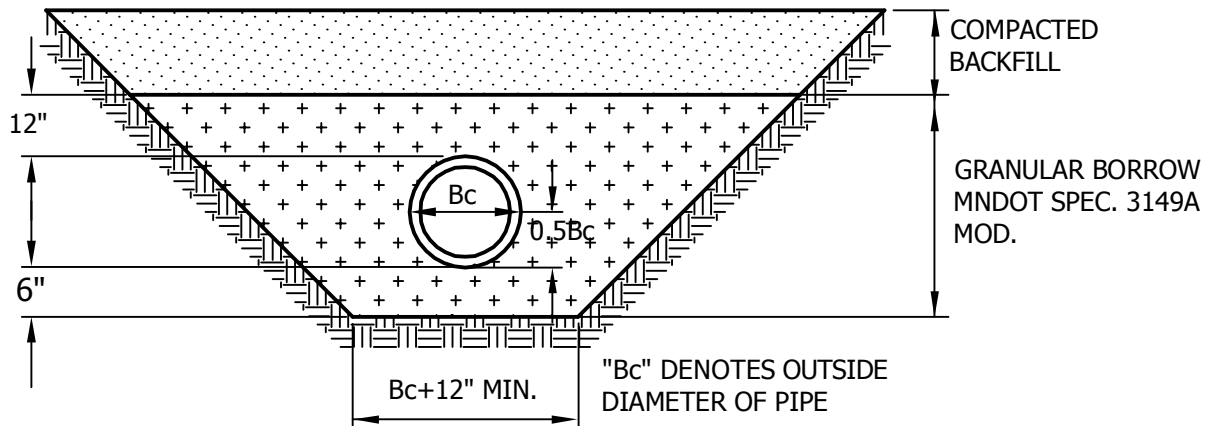

PIPE FOUNDATION & BEDDING IN GOOD SOILS

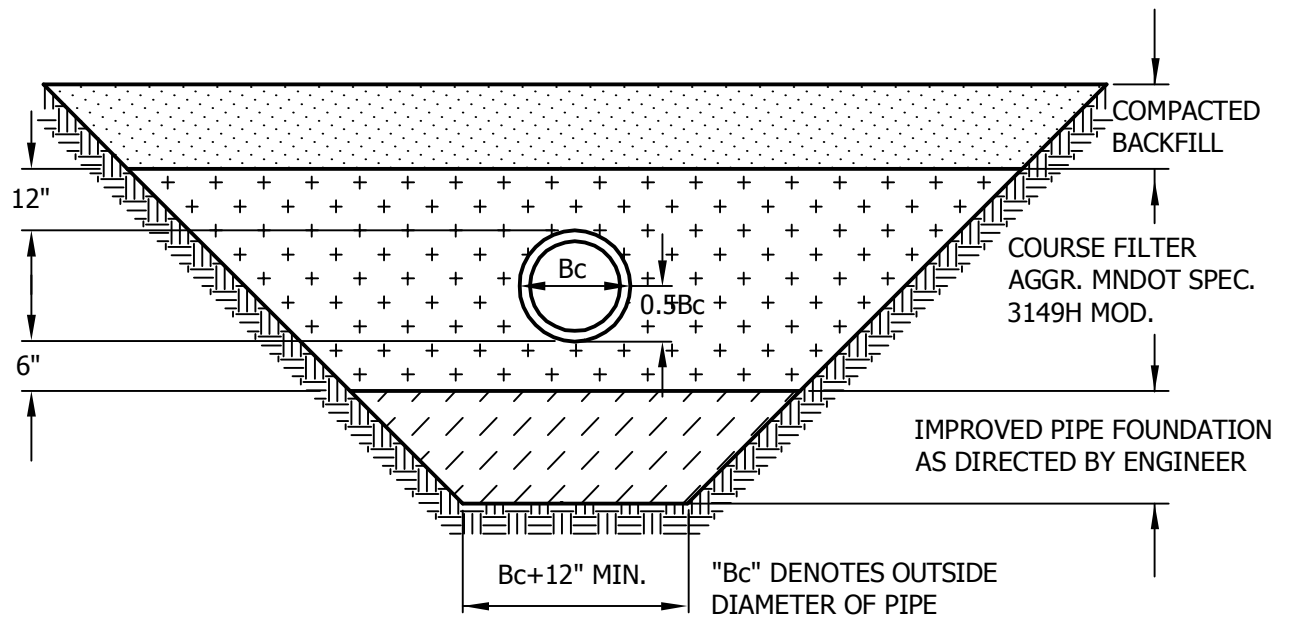

PIPE FOUNDATION & BEDDING IN POOR SOILS



**STANDARD DETAILS**  
BEDDING METHODS FOR HDPE

**SPRING LAKE TOWNSHIP**

Last Revision:  
JAN 2010

Plate No.  
STO-16

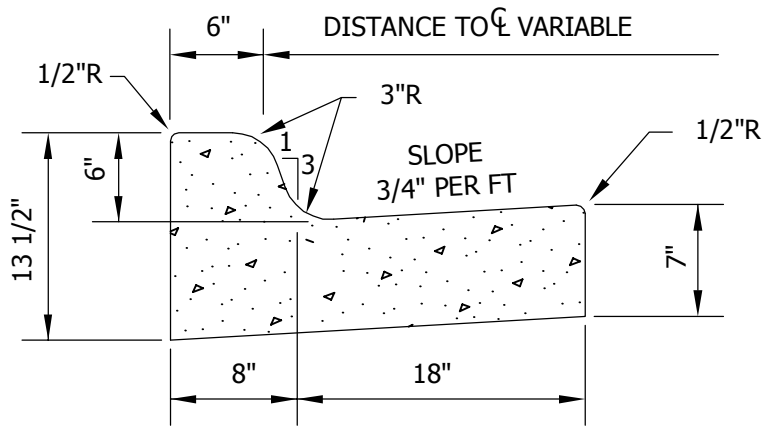

MNDOT B618

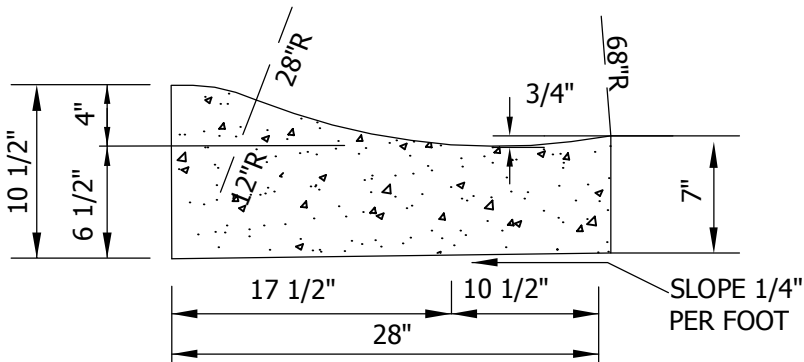

SURMOUNTABLE

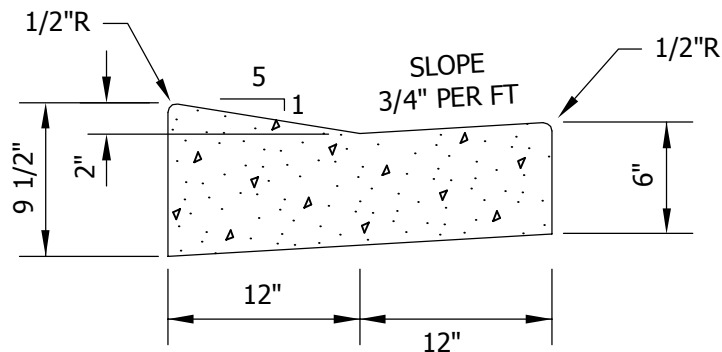

DRIVEWAY

SURMOUNTABLE

(16" - B618)



STANDARD DETAILS  
CURB AND GUTTER

Last Revision:

JAN 2010

Plate No.

STR-1

SPRING LAKE TOWNSHIP

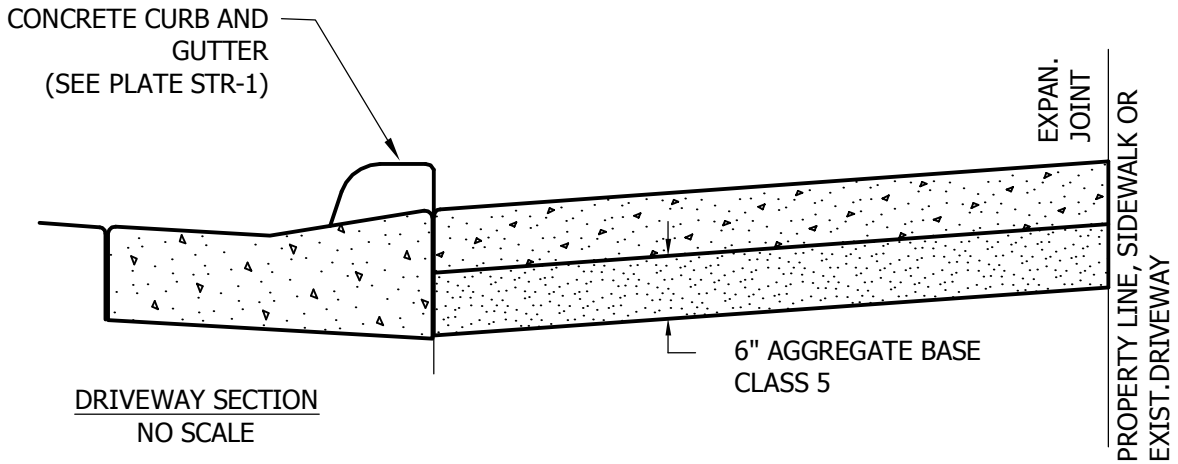

DRIVEWAY SECTION  
NO SCALE

1. PANEL WIDTH SHALL NOT EXCEED 10 FEET WITHOUT A CONTRACTION JOINT.
2. DRIVEWAY TO BE ONE COURSE CONCRETE PAVEMENT.
3. 6" THICK FOR RESIDENTIAL DRIVE, 8" THICK FOR COMMERCIAL DRIVE AND ALLEY OR SPECIFIED.
4. MAXIMUM DRIVEWAY WIDTH = 24' AS MEASURED 5 FEET FROM THE BACK OF CURB.
5. ALL DRIVEWAYS MUST BE AT LEAST 60' FROM INTERSECTIONS MEASURED FROM CENTERLINE/CENTERLIN TO CENTER OF DRIVEWAY.

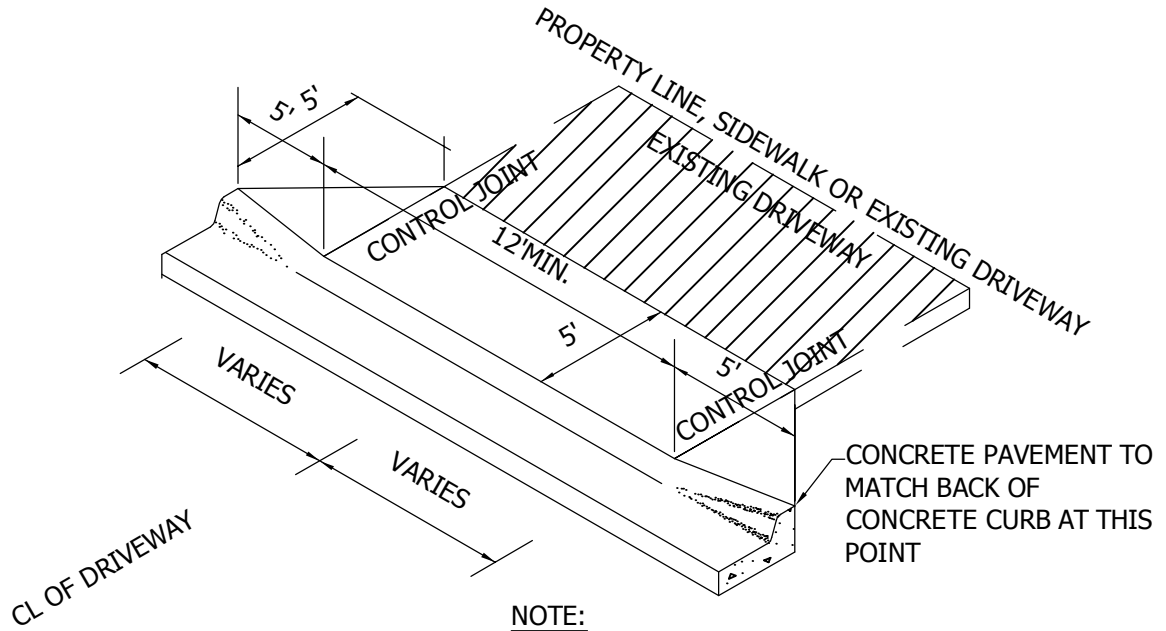

DRIVEWAY ISOMETRIC  
NO SCALE

NOTE:  
CONTROL JOINTS IN CONCRETE CURB NOT TO EXCEED 10' SPACING THROUGH DRIVEWAY SECTION.



**STANDARD DETAILS**  
CONCRETE DRIVEWAY APRON

SPRING LAKE TOWNSHIP

Last Revision:

JAN 2010

Plate No.

STR-2

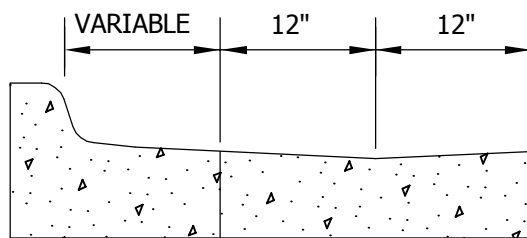
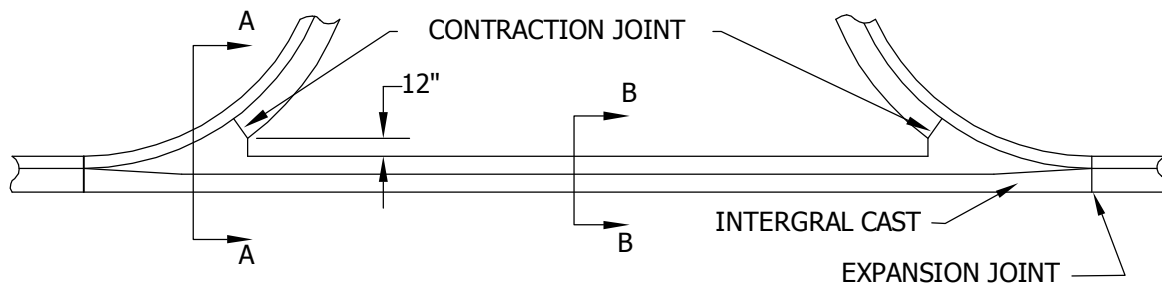

SECTION A-A  
THRU B618 C&G

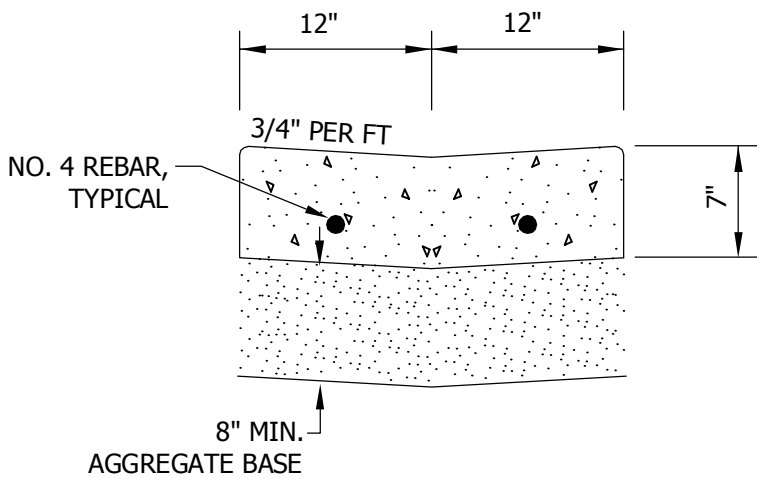

SECTION B-B THRU  
CONCRETE GUTTER



**STANDARD DETAILS**  
COMMERCIAL DRIVEWAY SECTION

SPRING LAKE TOWNSHIP

Last Revision:

JAN 2010

Plate No.

STR-3

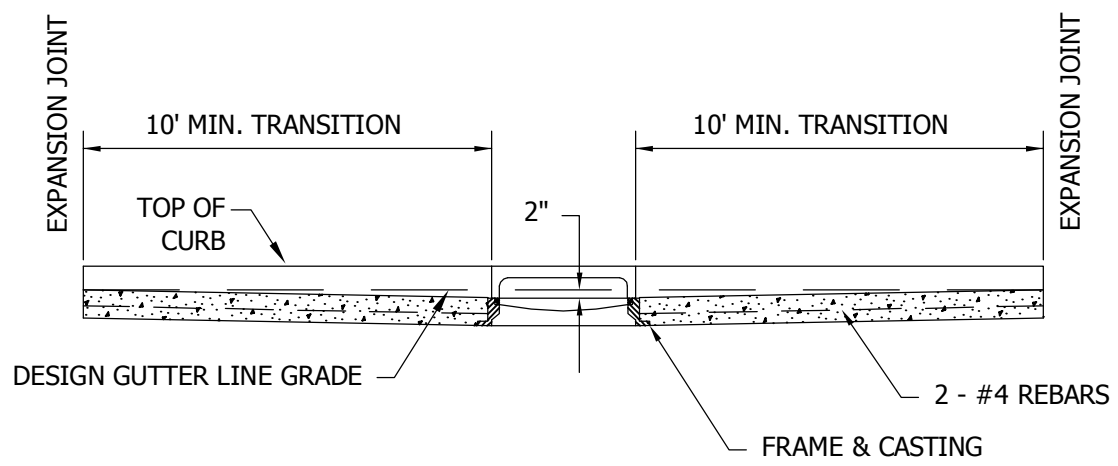
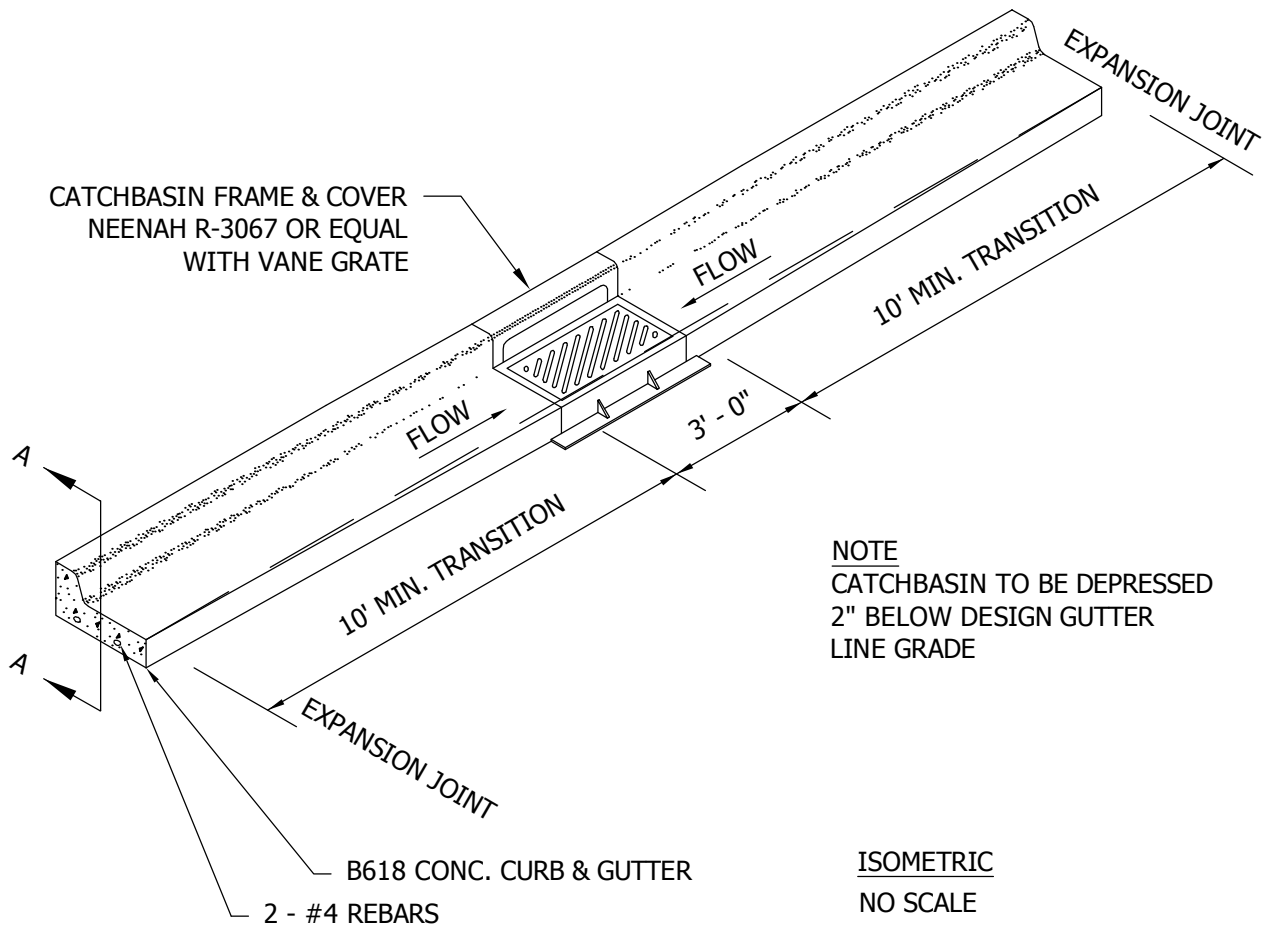

SECTION A-A  
NO SCALE

	<p><b>STANDARD DETAILS</b></p> <p>B618 CURB &amp; GUTTER CONSTRUCTION AT CATCH BASIN</p>	<p>Last Revision:</p> <p><b>JAN 2010</b></p>
	<p><b>SPRING LAKE TOWNSHIP</b></p>	<p>Plate No.</p> <p><b>STR-4</b></p>



NOTE:  
SURMOUNTABLE CURB & GUTTER TO BE FORMED  
INTO A B618 TYPE AT CATCHBASIN.

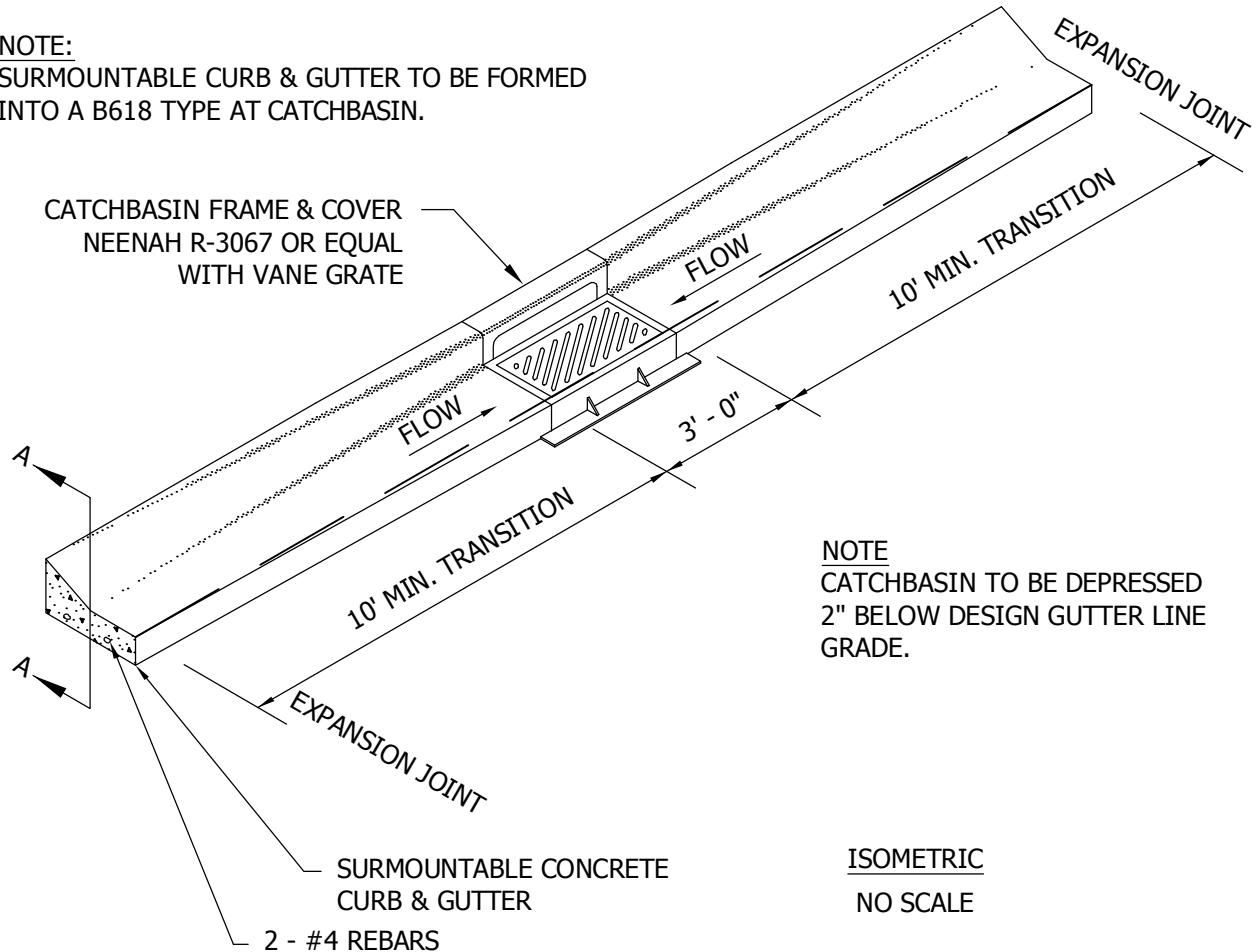

NOTE  
CATCHBASIN TO BE DEPRESSED  
2" BELOW DESIGN GUTTER LINE GRADE.

ISOMETRIC  
NO SCALE

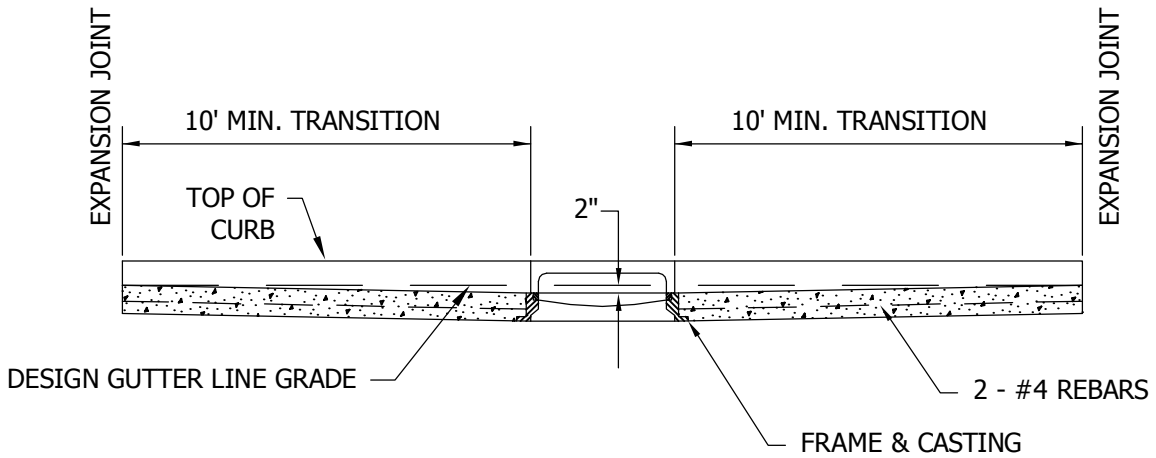

SECTION A-A  
NO SCALE



**STANDARD DETAILS**

SURMOUNTABLE CURB & GUTTER  
CONSTRUCTION AT CATCH BASIN

SPRING LAKE TOWNSHIP

Last Revision:

JAN 2010

Plate No.

STR-5

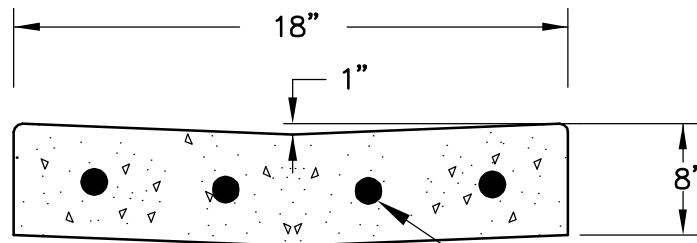
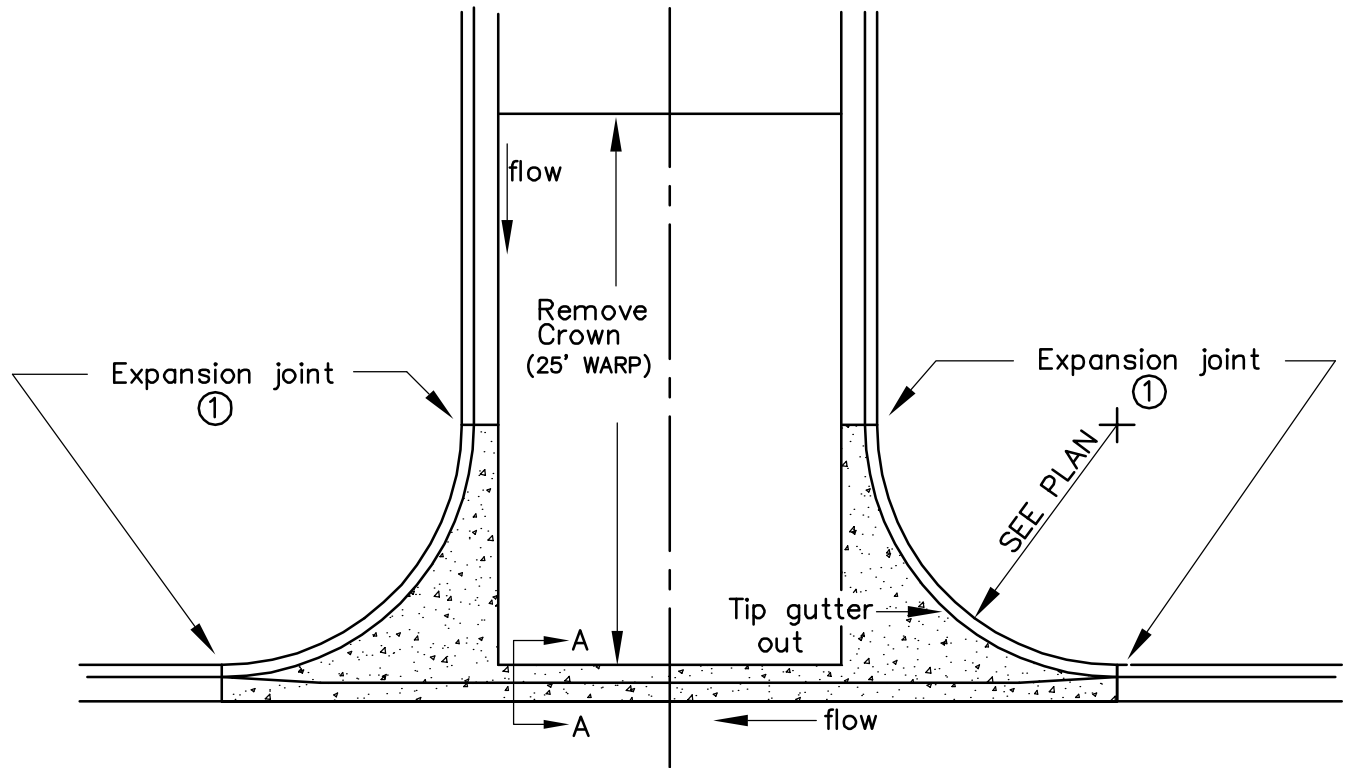

**SECTION A-A**

#4 REBAR @ 3.6" O.C.

**NOTES:**

1. 1/2" Preformed joint filler material – AASHTO M213.
2. No Contraction Joints in Cross Gutter.



**STANDARD DETAILS**  
CONCRETE VALLEY GUTTER

**SPRING LAKE TOWNSHIP**

Last Revision:

JAN 2010

Plate No.

STR-6

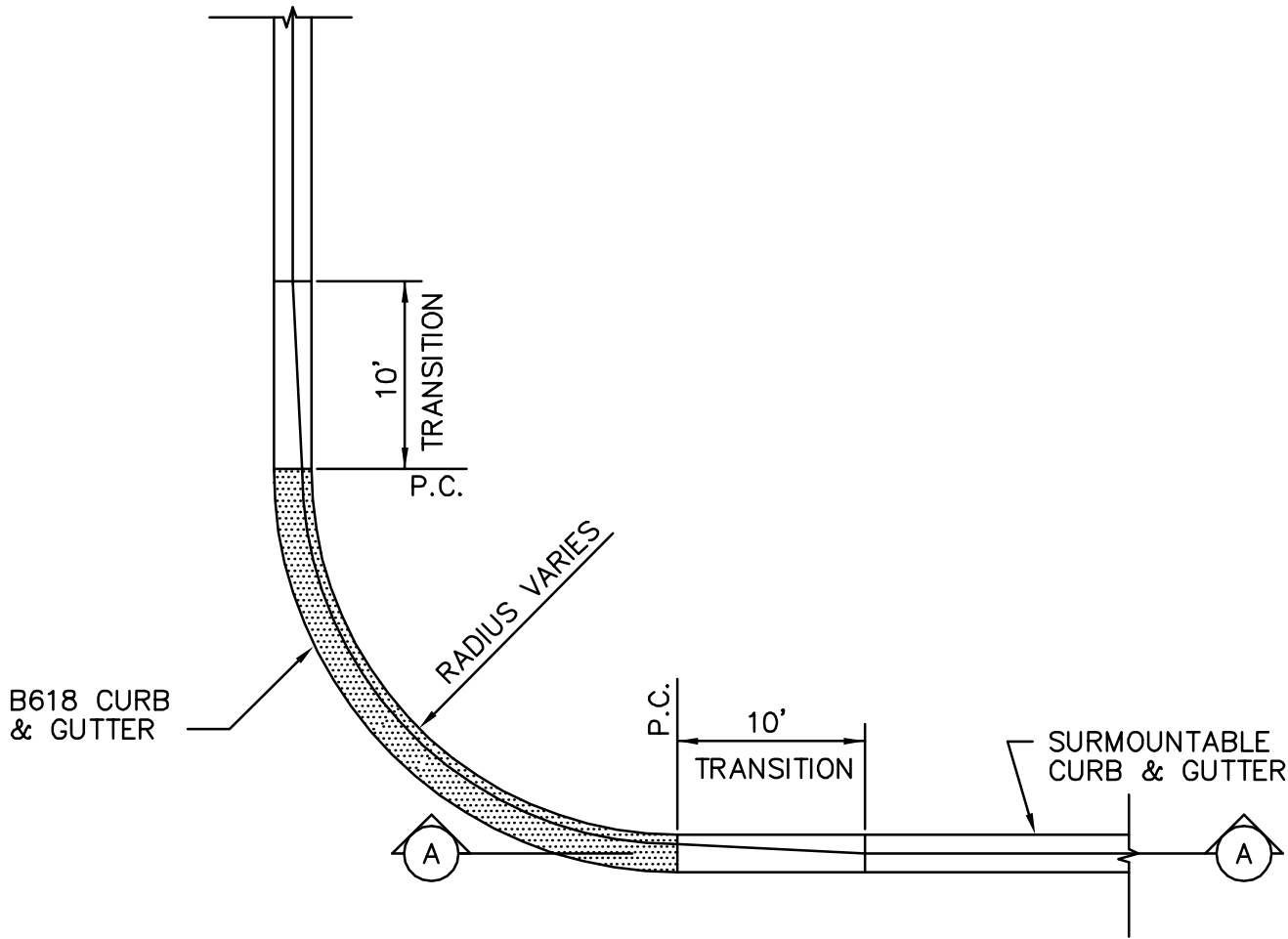

TYPICAL RESIDENTIAL RADIUS - 20'  
 TYPICAL COLLECTOR RADIUS - 30'

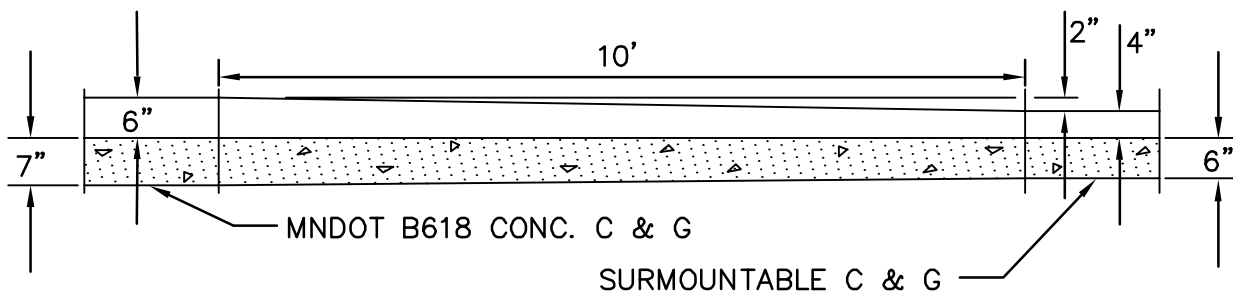

**SECTION A-A**



**STANDARD DETAILS**  
 TYPICAL CURB RADIUS

**SPRING LAKE TOWNSHIP**

Last Revision:

JAN 2010

Plate No.

STR-7

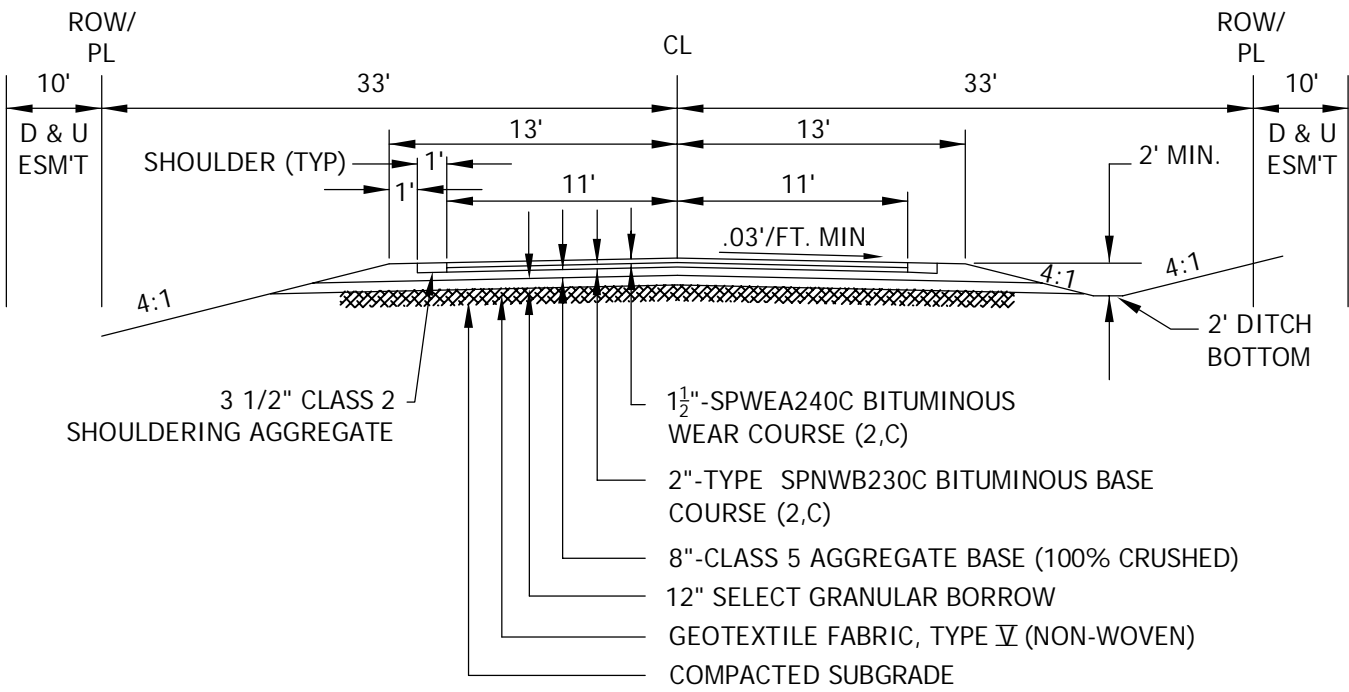

**NOTES**

ALL ORGANIC OR OTHER UNSUITABLE MATERIALS SHALL BE REMOVED FROM BENEATH THE ROADWAY.

A TEST ROLL OF THE PREPARED SUBGRADE SHALL BE PERFORMED IN THE PRESENCE OF A TOWNSHIP INSPECTOR. THE TOWNSHIP HAS THE AUTHORITY TO REQUIRE ADDITIONAL SUBGRADE CORRECTION OR ELIMINATE THE STABILIZATION FABRIC.

THE TOWNSHIP RESERVES THE RIGHT TO MODIFY STREET SECTION AS REQUIRED.

NO CONCRETE WORK OR BITUMINOUS PAVING SHALL OCCUR AFTER OCTOBER 31ST UNLESS AUTHORIZED BY THE TOWNSHIP OF SPRING LAKE.



**STANDARD DETAILS**  
TYPICAL SECTION FOR LOCAL STREET  
RURAL SECTION

**SPRING LAKE TOWNSHIP**

Last Revision:

FEB. 2016

Plate No.

STR-8

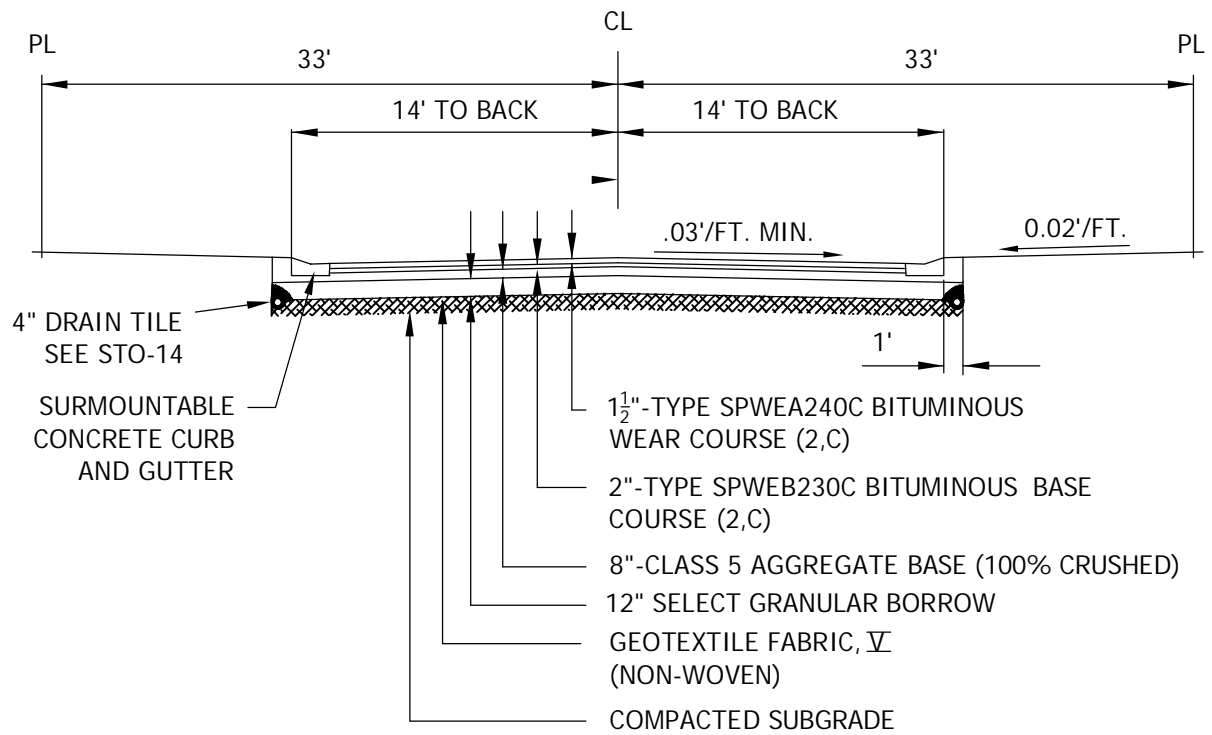

**NOTES**

ALL ORGANIC OR OTHER UNSUITABLE MATERIALS SHALL BE REMOVED FROM BENEATH THE ROADWAY.

A TEST ROLL OF THE PREPARED SUBGRADE SHALL BE PERFORMED IN THE PRESENCE OF A TOWNSHIP INSPECTOR. THE TOWNSHIP HAS THE AUTHORITY TO REQUIRE ADDITIONAL SUBGRADE CORRECTION OR ELIMINATE THE STABILIZATION FABRIC.

THE TOWNSHIP RESERVES THE RIGHT TO MODIFY STREET SECTION AS REQUIRED.

NO CONCRETE WORK OR BITUMINOUS PAVING SHALL OCCUR AFTER OCTOBER 31ST UNLESS AUTHORIZED BY THE TOWNSHIP.



**STANDARD DETAILS**  
 TYPICAL SECTION FOR LOCAL STREET  
 URBAN SECTION (PUBLIC)

**SPRING LAKE TOWNSHIP**

Last Revision:

FEB. 2016

Plate No.

STR-9

TOWNSHIP CONNECTOR

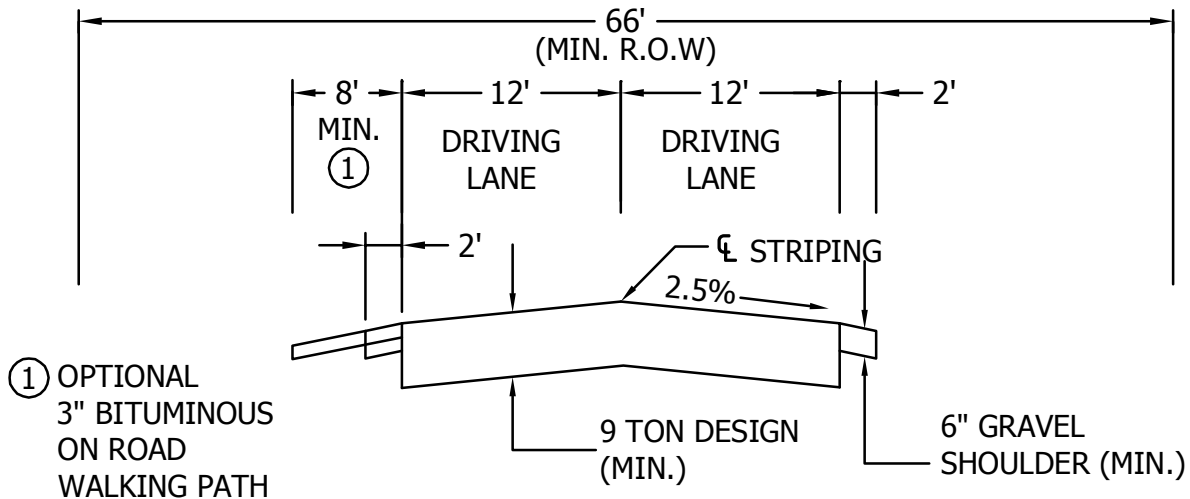

OTHER SPECS.

- 30 MPH DESIGN SPEED WHERE POSSIBLE
- LIMIT DRIVEWAY ACCESS WHERE POSSIBLE
- ADDITIONAL R.O.W. FOR CULVERTS, TURN/BYPASS LANES, TRAILS, AND OTHER TOPOGRAPHICAL NEEDS

TOWNSHIP COLLECTOR

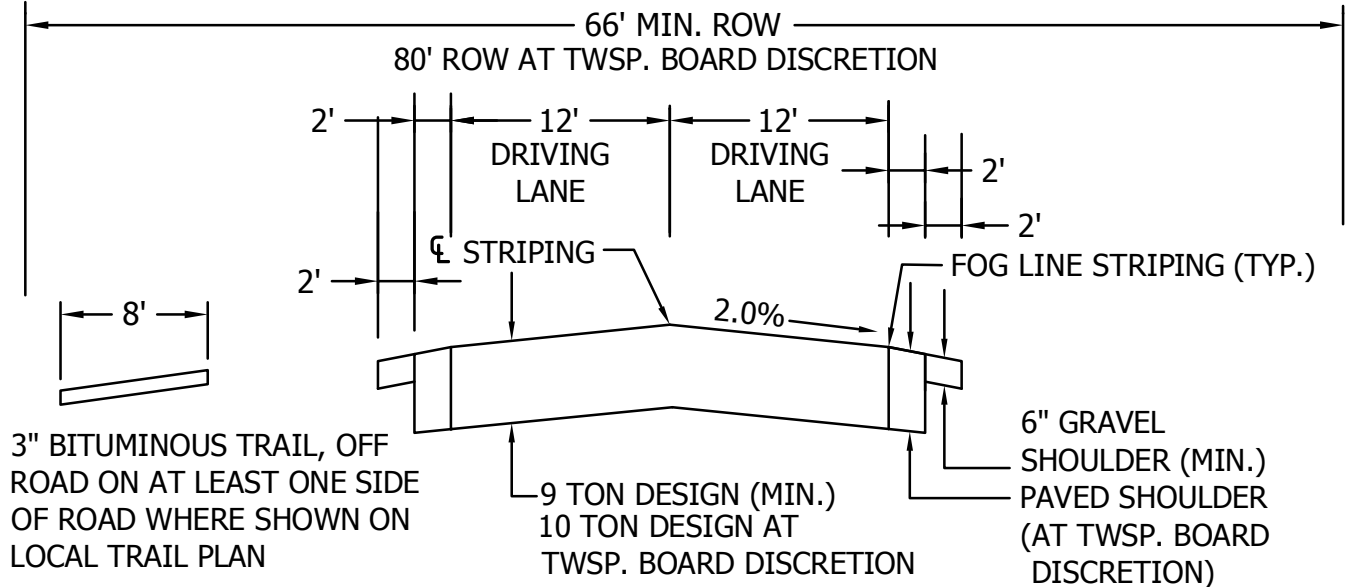

OTHER SPECS.

- 45 MPH DESIGN SPEED ENCOURAGED (30 MPH MIN.)
- NO DIRECT DRIVEWAY ACCESS FOR NEW SUBDIVISIONS UNLESS 660' FROM NEAREST DRIVEWAY
- ADDITIONAL R.O.W. FOR CULVERTS, TURN/BYPASS LANES, TRAILS, AND OTHER TOPOGRAPHICAL NEEDS



**STANDARD DETAILS**  
TYPICAL SECTION FOR  
COLLECTOR/CONNECTOR STREET

**SPRING LAKE TOWNSHIP**

Last Revision:

JAN 2010

Plate No.

STR-10

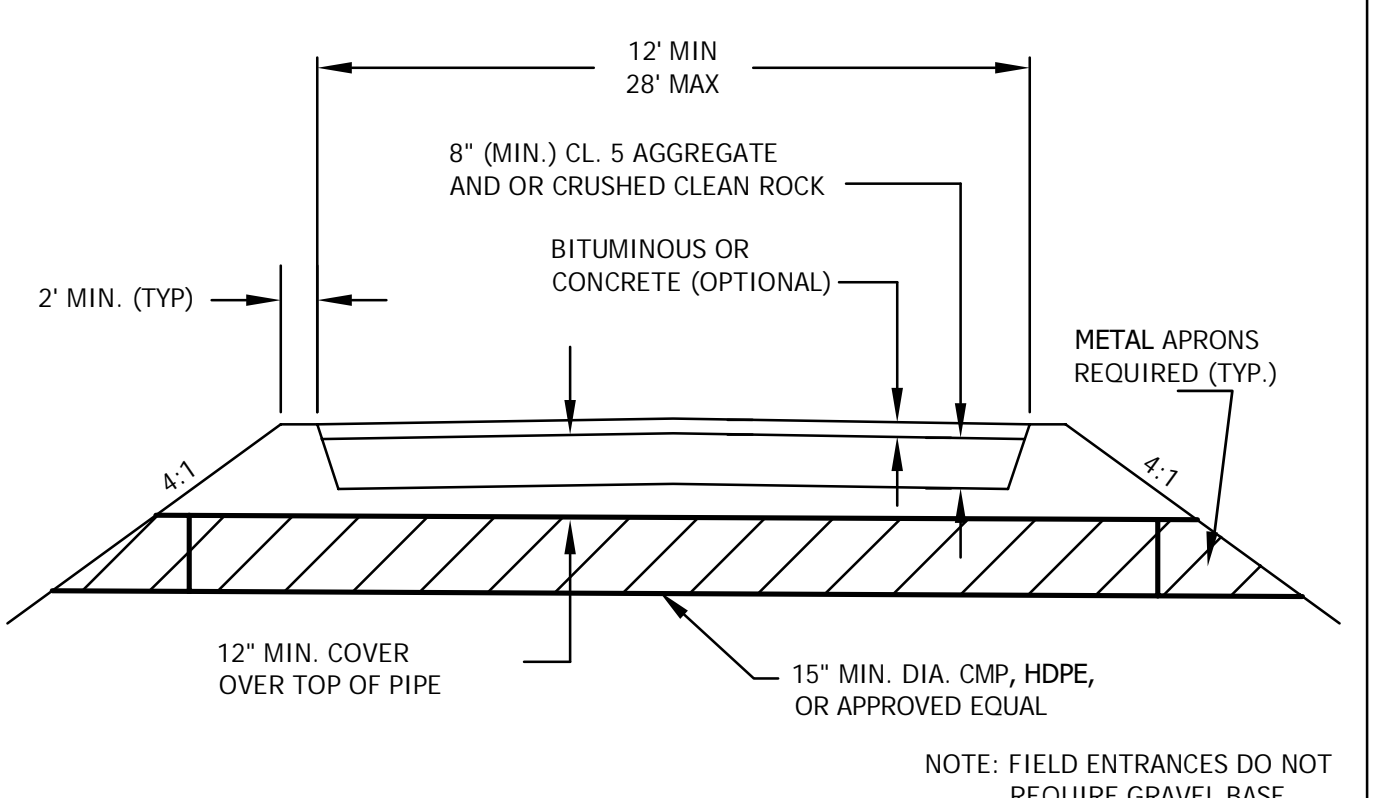
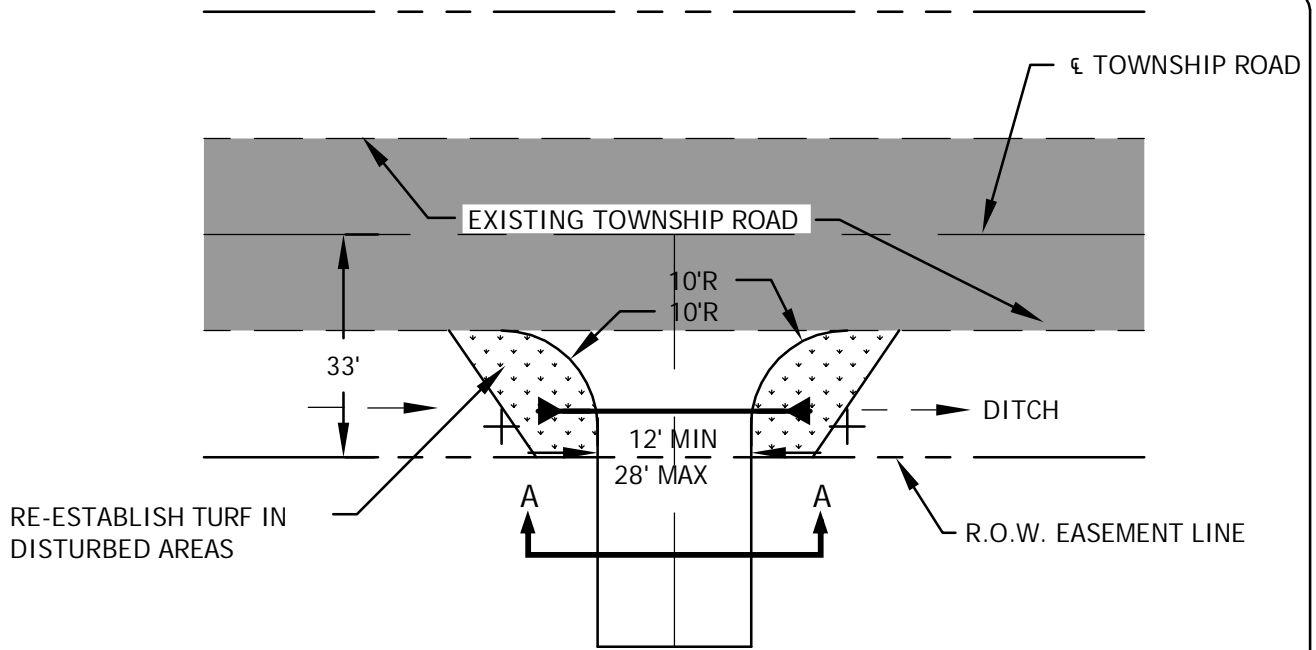

**SECTION AA**

2335 Highway 36 W  
St. Paul, MN 55113  
www.stantec.com

**STANDARD DETAILS**  
TYPICAL DRIVEWAY

**SPRING LAKE TOWNSHIP**

Last Revision:  
**JAN 2010**

Plate No.  
**STR-11**

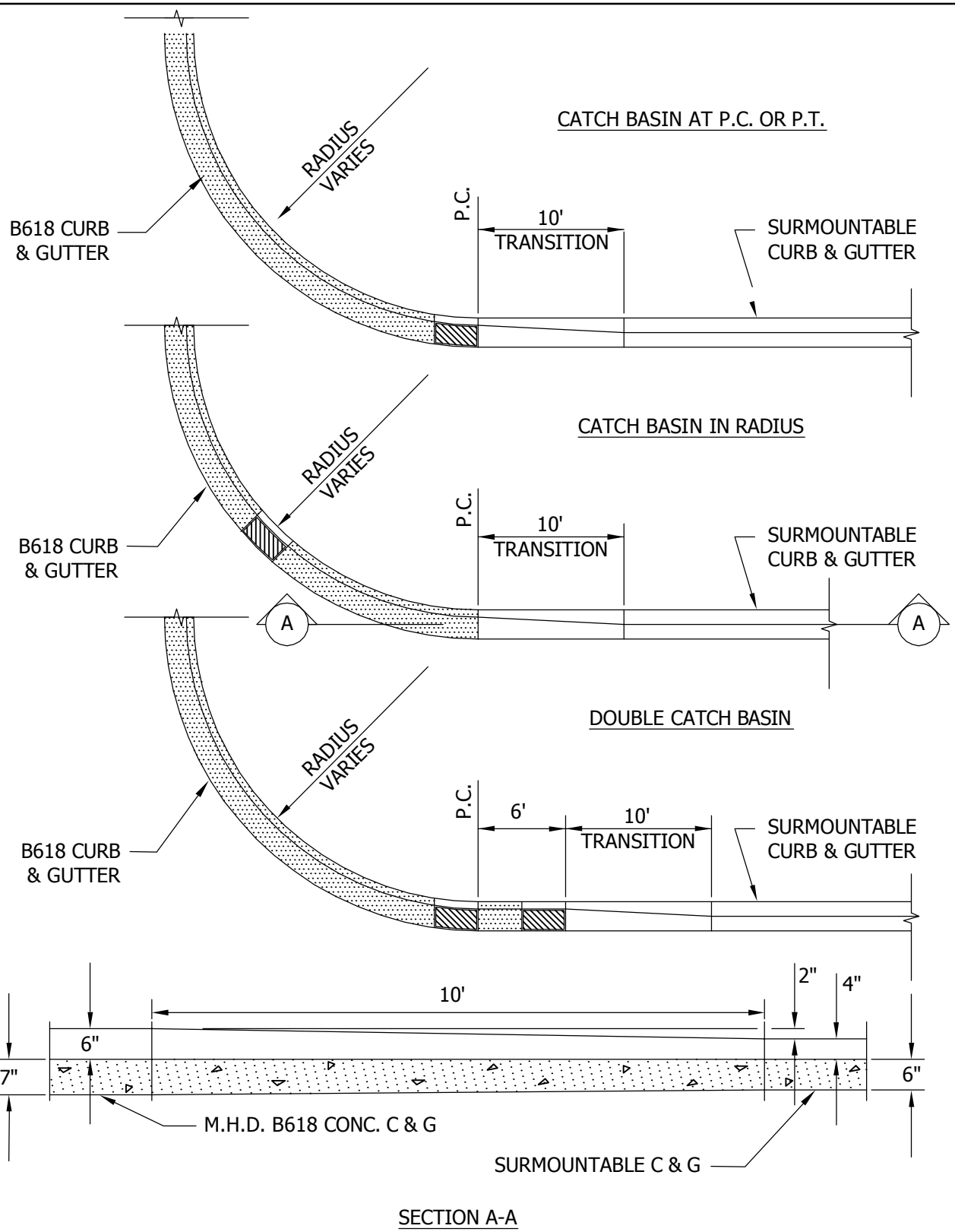

**STANDARD DETAILS**  
**CONCRETE CURB & GUTTER**  
**TRANSITION**

**SPRING LAKE TOWNSHIP**

Last Revision:  
**JAN 2010**

Plate No.  
**STR-12**



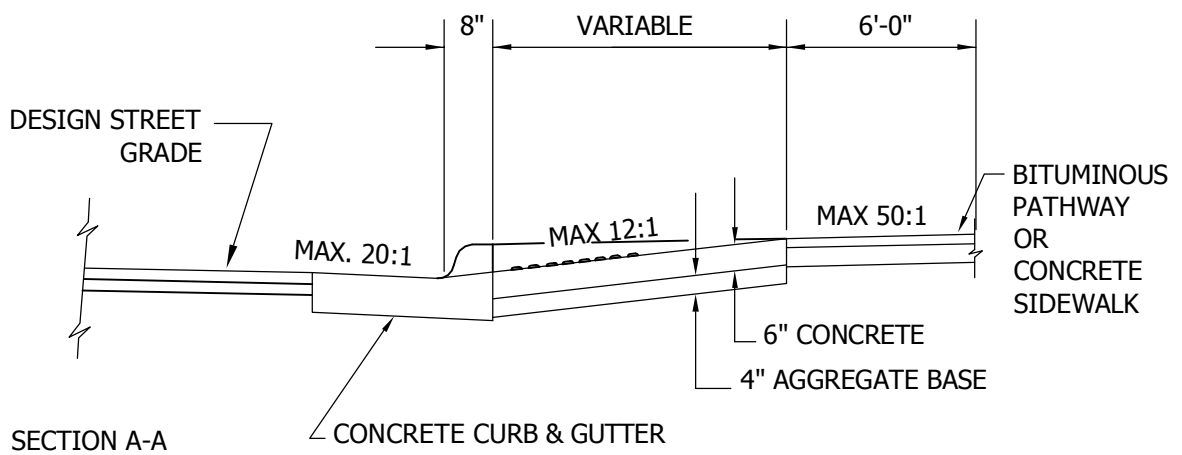
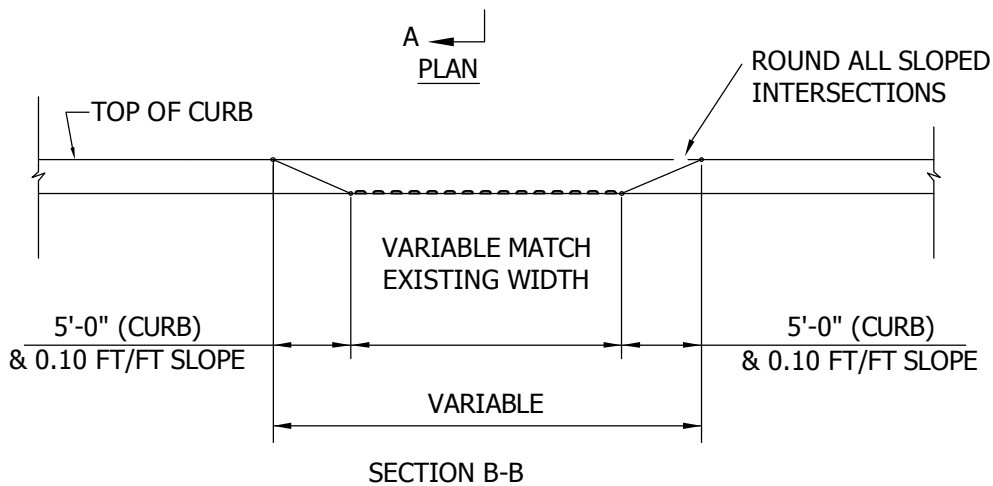
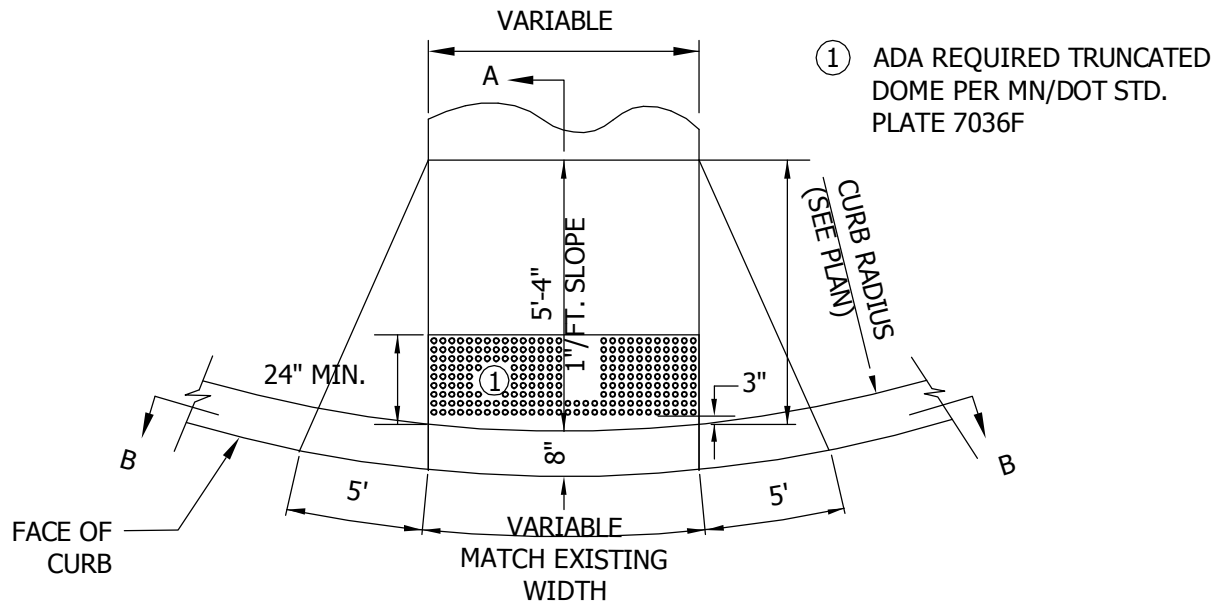

**STANDARD DETAILS**  
 PEDESTRIAN CURB RAMP  
 FOR PATHWAY / SIDEWALK

**SPRING LAKE TOWNSHIP**

Last Revision:

JAN 2010

Plate No.

STR-13

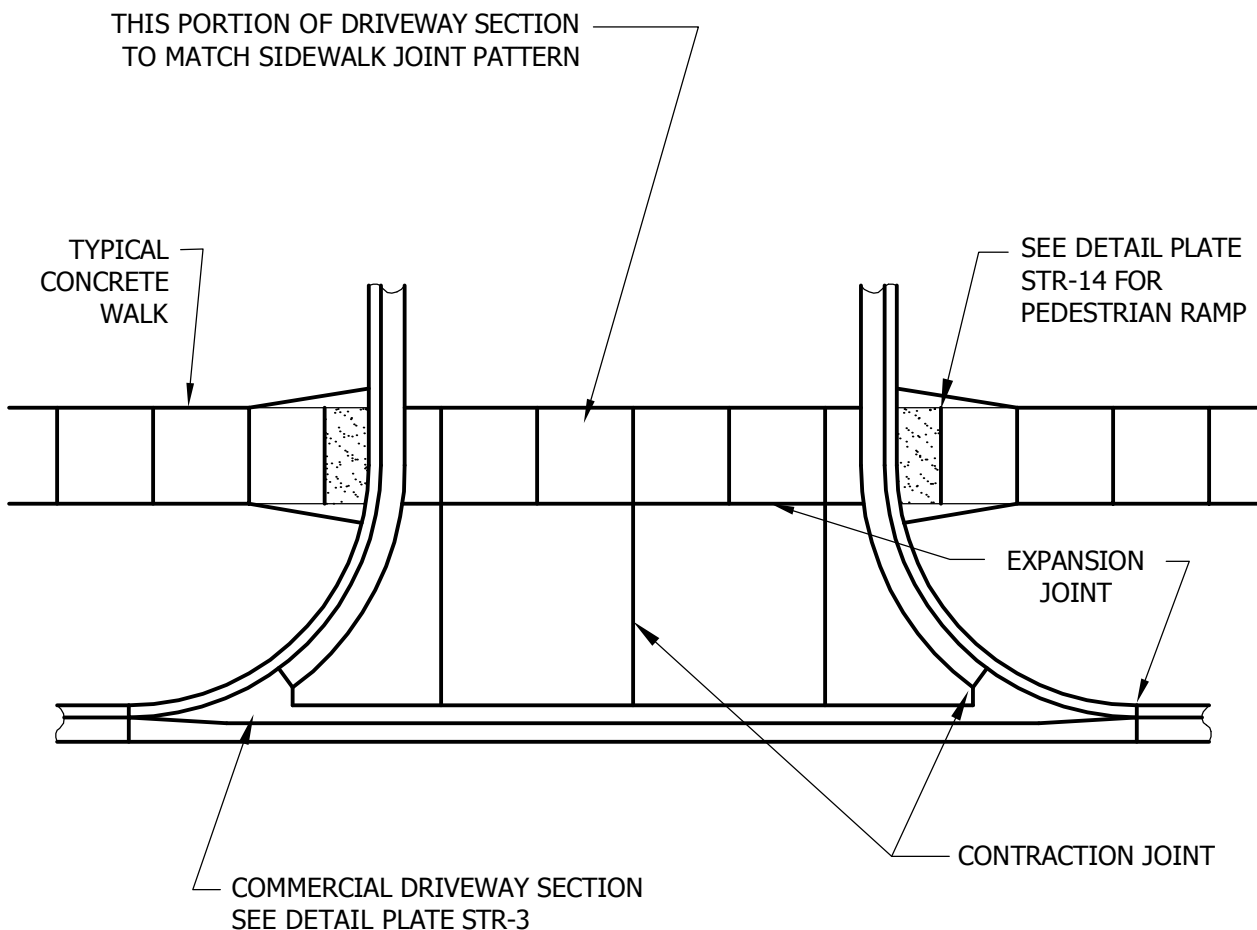

SEE DRIVEWAY DETAIL PLATE STR-2 FOR  
CONCRETE THICKNESS AND PANEL WIDTH



**STANDARD DETAILS**

TYPICAL SECTION FOR SIDEWALK  
ACROSS COMMERCIAL DRIVEWAY

**SPRING LAKE TOWNSHIP**

Last Revision:

JAN 2010

Plate No.

STR-14

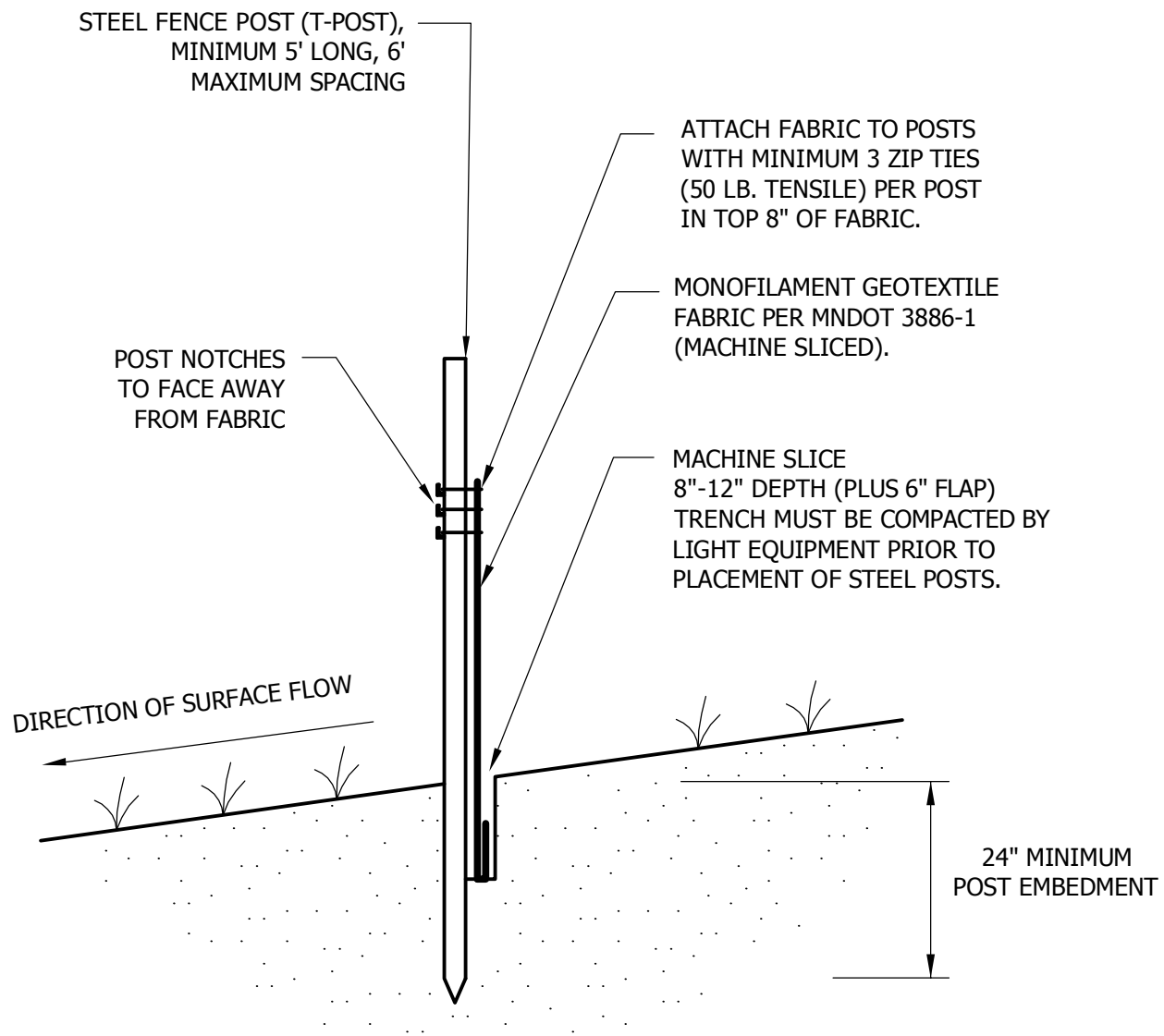

**NOTE:**  
 THE MACHINE SLICED METHOD (THIS DETAIL) IS THE STANDARD SILT FENCE INSTALLATION METHOD. HEAVY-DUTY (ERO-1B) OR STANDARD (ERO-1C) SILT FENCE INSTALLATION METHODS SHOULD ONLY BE USED WHEN APPROVED OR DIRECTED BY THE ENGINEER.



**STANDARD DETAILS**  
 SILT FENCE  
 MACHINE SLICED

**SPRING LAKE TOWNSHIP**

Last Revision:  
 JAN 2010

Plate No.  
 ERO-1A

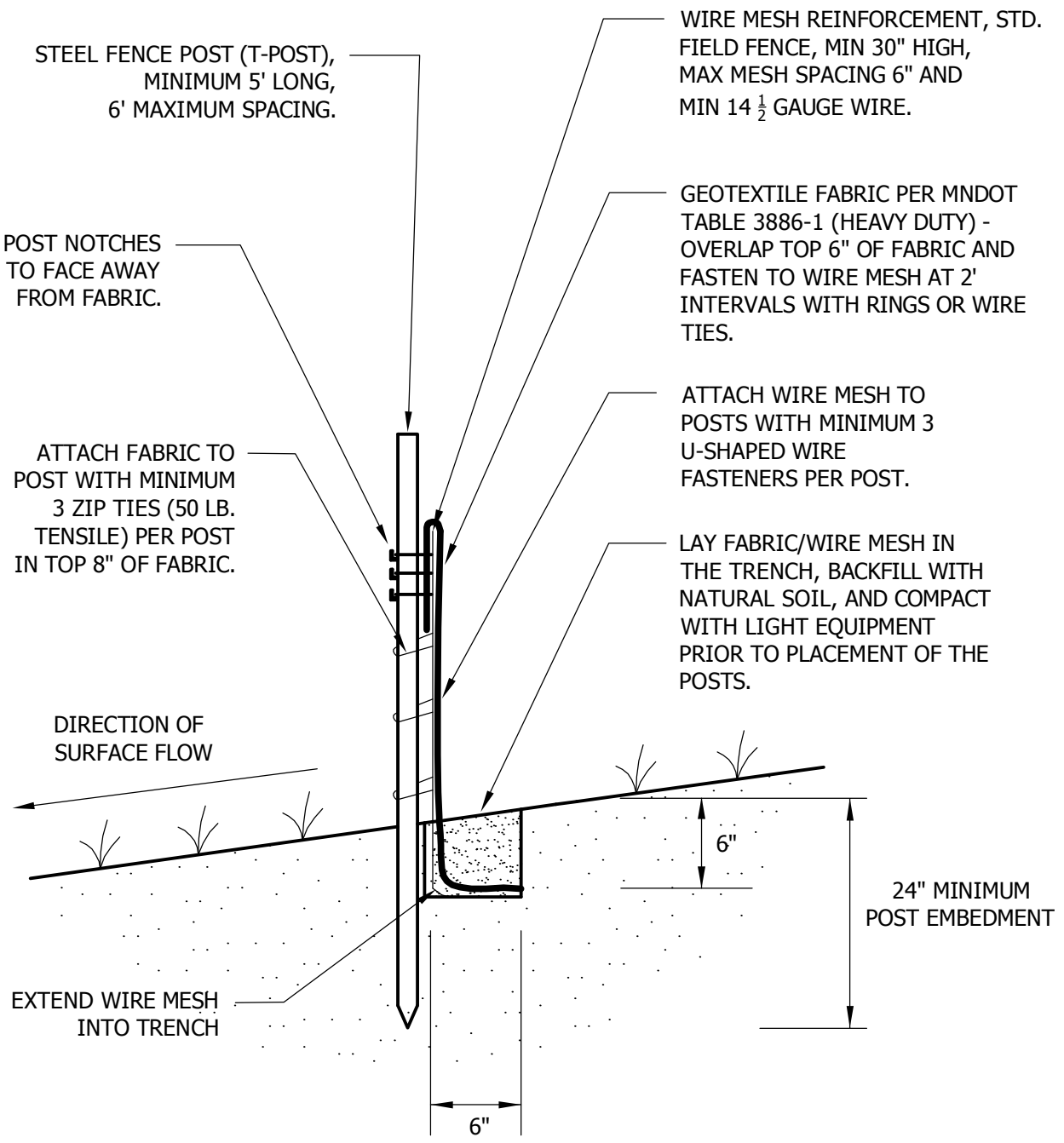

**STANDARD DETAILS**

SILT FENCE  
HEAVY DUTY

SPRING LAKE TOWNSHIP

Last Revision:

JAN 2010

Plate No.

ERO-1B

STEEL FENCE POST (T-POST),  
MINIMUM 5' LONG,  
6' MAXIMUM SPACING.

MONOFILAMENT GEOTEXTILE  
FABRIC PER MNDOT 3886-1  
(MACHINE SLICED).

ATTACH FABRIC TO POST WITH  
MINIMUM 3 ZIP TIES (50 LB.  
TENSILE) PER POST IN TOP 8"  
OF FABRIC.

POST NOTCHES  
TO FACE AWAY  
FROM FABRIC.

LAY FABRIC IN THE TRENCH,  
BACKFILL WITH NATURAL  
SOIL, AND COMPACT WITH  
LIGHT EQUIPMENT PRIOR TO  
PLACEMENT OF THE POSTS.

DIRECTION OF  
SURFACE FLOW

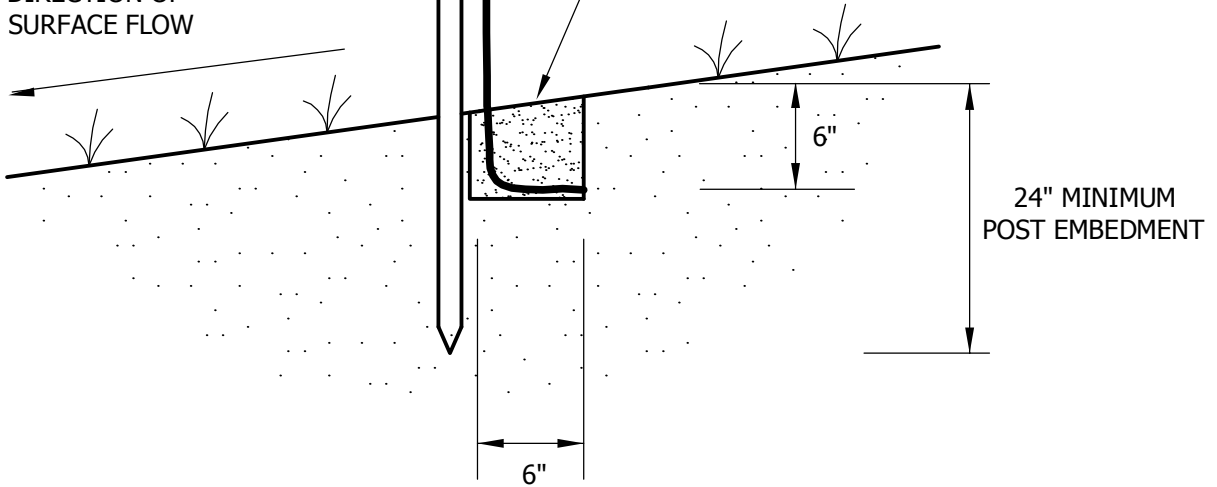

**STANDARD DETAILS**

SILT FENCE  
STANDARD

Last Revision:

JAN 2010

Plate No.

SPRING LAKE TOWNSHIP

ERO-1C

PLAN VIEW

I. SPACING REQUIREMENTS

DIRECTION OF SURFACE FLOW



NOTE: SPACING DISTANCES WILL VARY, BUT ARE NOT TO EXCEED 100 FEET.

II. SIZING REQUIREMENTS: J15, J25

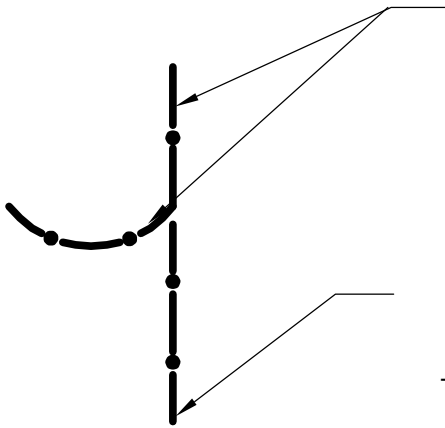

UP-GRADIENT SILT FENCE AND J-HOOK ARE ONE CONTINUOUS LINE

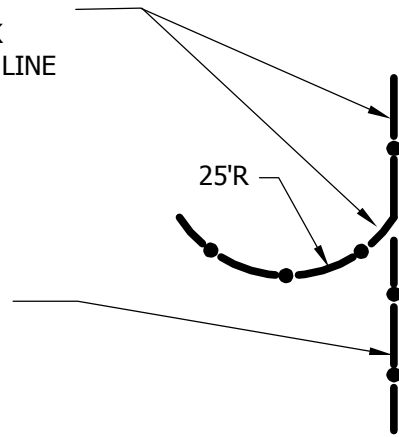

START DOWN-GRADIENT SILT FENCE LINE AS CLOSE AS POSSIBLE TO THE UP-GRADIENT J-HOOK

J15 - FOR CATCHMENT AREA < 0.25 ACRES

J25 - FOR CATCHMENT AREA ≥ 0.25 ACRES

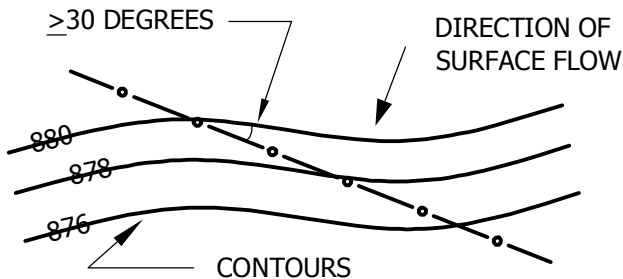

NOTE: J-HOOKS SHALL BE USED WHEN THE SILT FENCE IS INSTALLED AT AN ANGLE OF 30 DEGREES OR GREATER FROM PARALLEL TO THE CONTOURS.



STANDARD DETAILS

SILT FENCE  
J-HOOK

SPRING LAKE TOWNSHIP

Last Revision:

JAN 2010

Plate No.

ERO-1D

ANCHOR TRENCH (SEE DETAIL AND NOTES BELOW)

BLANKET TYPE SHALL CONFORM TO DRAWINGS AND SPECIFICATIONS.

OVERLAP END JOINTS MINIMUM OF 6" AND STAPLE OVERLAP AT 1.5' INTERVALS.

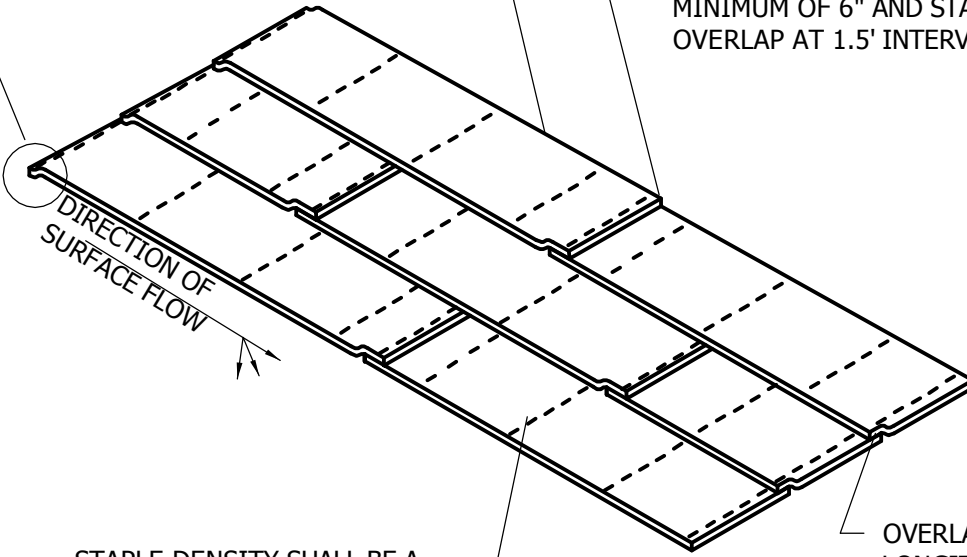

STAPLE DENSITY SHALL BE A MINIMUM OF 3 STAPLES PER SQUARE YARD OR PER THE ENGINEER'S INSTRUCTIONS.

OVERLAP LONGITUDINAL JOINTS MINIMUM OF 6"

\*NO METAL STAPLES ALLOWED\*

ANCHOR TRENCH

1. DIG 6" X 6" TRENCH
2. LAY BLANKET IN TRENCH
3. STAPLE AT 1.5' INTERVALS
4. BACKFILL WITH NATURAL SOIL AND COMPACT
5. BLANKET LENGTH SHALL NOT EXCEED 100' WITHOUT AN ANCHOR TRENCH

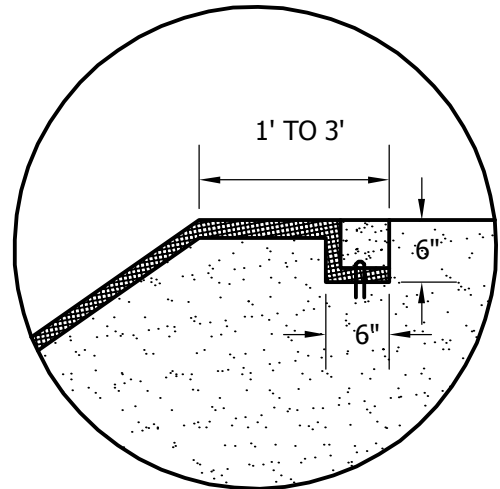

**STANDARD DETAILS**  
EROSION CONTROL BLANKET  
INSTALLATION

SPRING LAKE TOWNSHIP

Last Revision:

JAN 2010

Plate No.

ERO-2

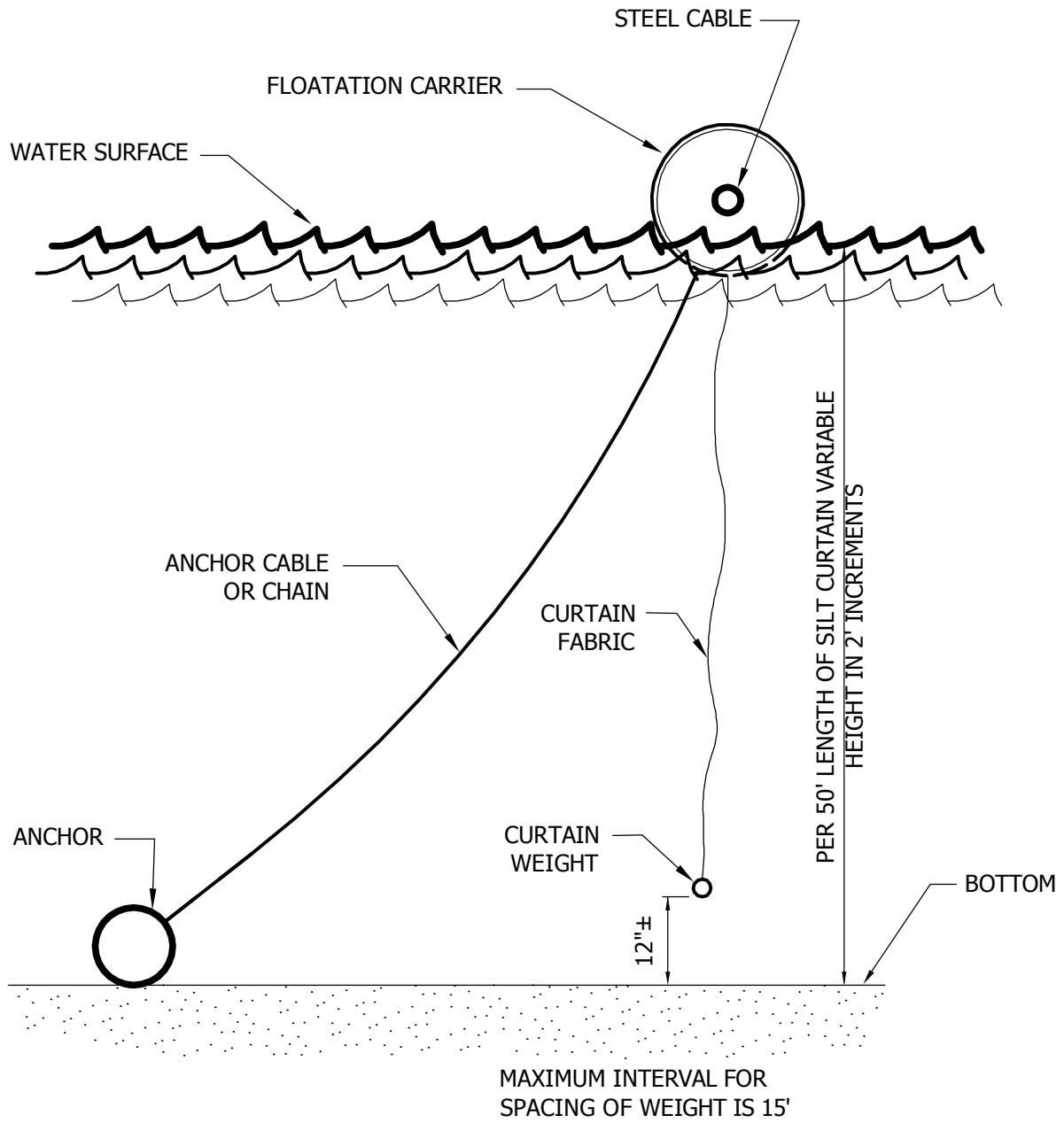

NOTE: DOUBLE SILT FENCES SHOULD BE SPACED 10' APART. CURTAIN LENGTH TO MATCH BOTTOM PROFILE AS CLOSELY AS POSSIBLE.

**STANDARD DETAILS**  
**FLOATING SILT FENCE**

Last Revision:  
**JAN 2010**

Plate No.  
**ERO-3**

**SPRING LAKE TOWNSHIP**





WOODEN LATH SHALL BE NAILED SECURELY TO THE POST MEMBER TO SECURE FILTER FABRIC.

2" X 4" HORIZONTAL MEMBERS CONTINUOUS AROUND TOP AND BOTTOM. FASTENED TO EACH POST USING 2-20D COMMON NAILS

2" X 4" X 2.5' LONG WOOD POSTS, 8 REQ'D.

MONOFILAMENT GEOTEXTILE (SILT FENCE) FABRIC, AS SPECIFIED. ADDITIONAL 8-10" OF FABRIC FLAP AT BOTTOM OF BOX

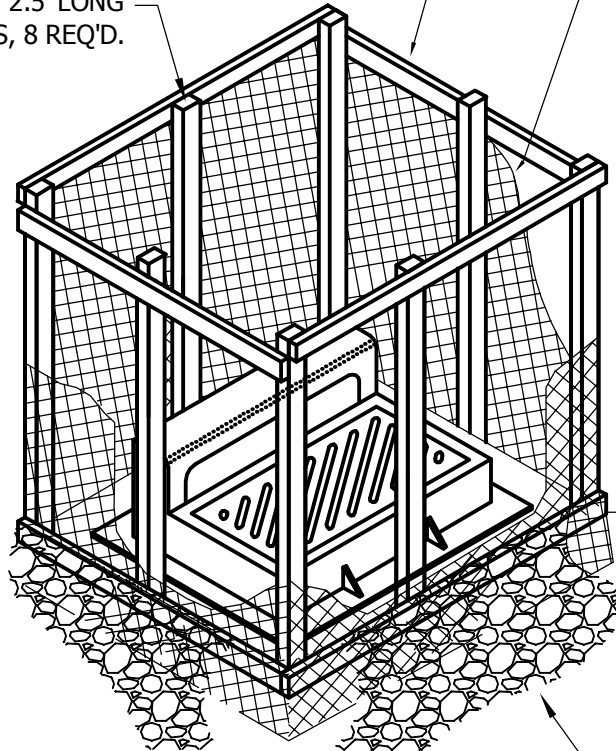

2'-6"

8-10" FABRIC FLAP EXTENDING BEYOND BOTTOM 2"X4" - BURY UNDER ROCK TO PREVENT UNDERWASHING

1 1/2" WASHED ROCK  
1' DEEP X 1' WIDE

**NOTES:**  
CONTRACTOR SHALL CONSTRUCT SILT BOX TO FIT AROUND THE INLET STRUCTURE WITH 6" MINIMUM CLEARANCE TO EDGES OF STRUCTURE. SILT BOX TO BE PLACED ON AN EVEN SURFACE 6" BELOW STRUCTURE OPENING. TOP OF SILT BOX TO EXTEND 18" MINIMUM ABOVE EXISTING GRADE.



**STANDARD DETAILS**  
INLET PROTECTION  
SILT BOX FOR CATCH BASIN  
BEFORE CURB CONSTRUCTION

**SPRING LAKE TOWNSHIP**

Last Revision:

JAN 2010

Plate No.

ERO-4A

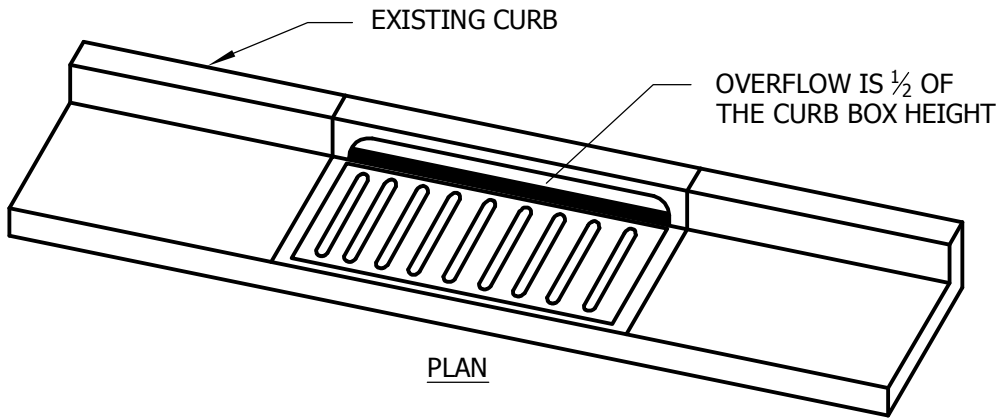

PLAN

WIMCO ROAD DRAIN CG-23 HIGH FLOW  
 INLET PROTECTION CURB AND GUTTER MODEL  
 OR CITY APPROVED EQUAL.

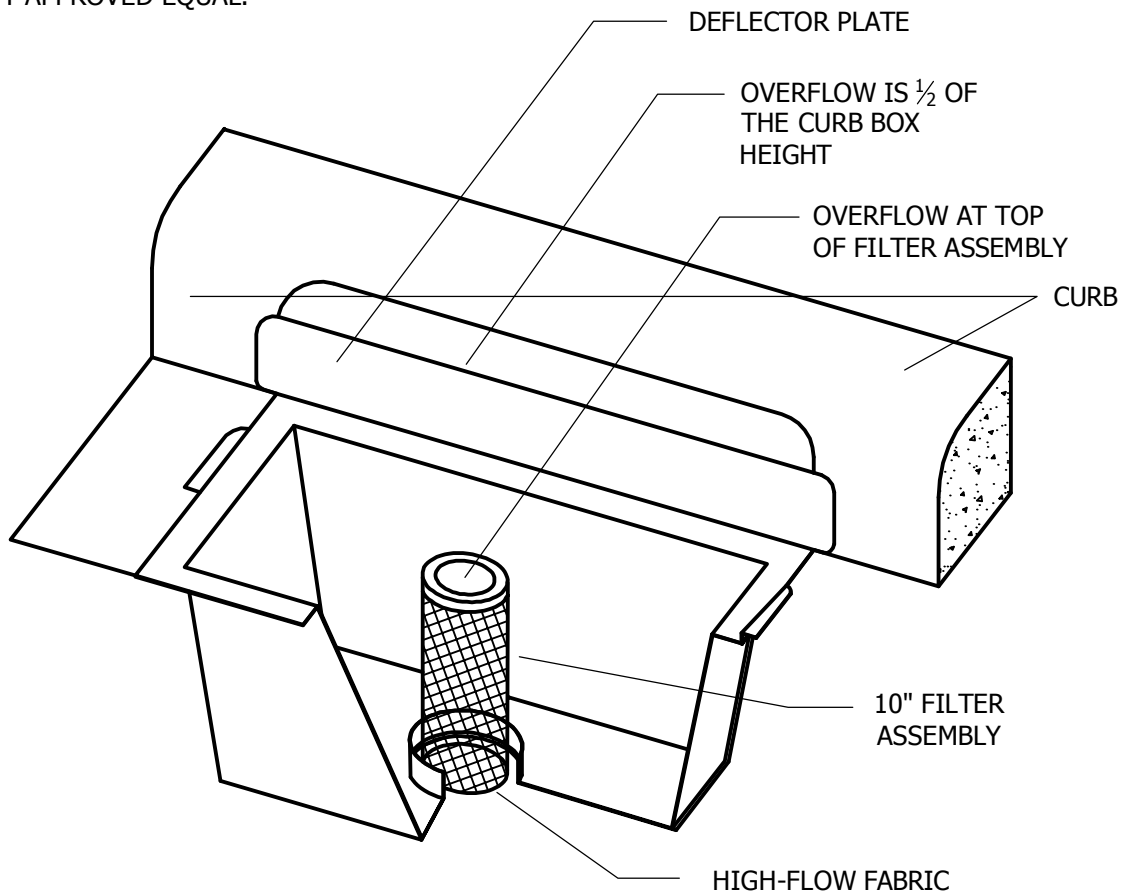

**STANDARD DETAILS**

INLET PROTECTION – CATCH BASIN  
 INSERT AFTER CURB CONSTRUCTION

**SPRING LAKE TOWNSHIP**

Last Revision:

JAN 2010

Plate No.

ERO-4B

WOODEN LATH SHALL BE NAILED SECURELY TO THE POST MEMBER TO SECURE FILTER FABRIC.

2" X 4" HORIZONTAL MEMBERS CONTINUOUS AROUND TOP AND BOTTOM. FASTENED TO EACH POST USING 2-20D COMMON NAILS

2" X 4" X 2.5' LONG WOOD POSTS, 8 REQ'D.

MONOFILAMENT GEOTEXTILE (SILT FENCE) FABRIC, AS SPECIFIED. ADDITIONAL 8-10" OF FABRIC FLAP AT BOTTOM OF BOX

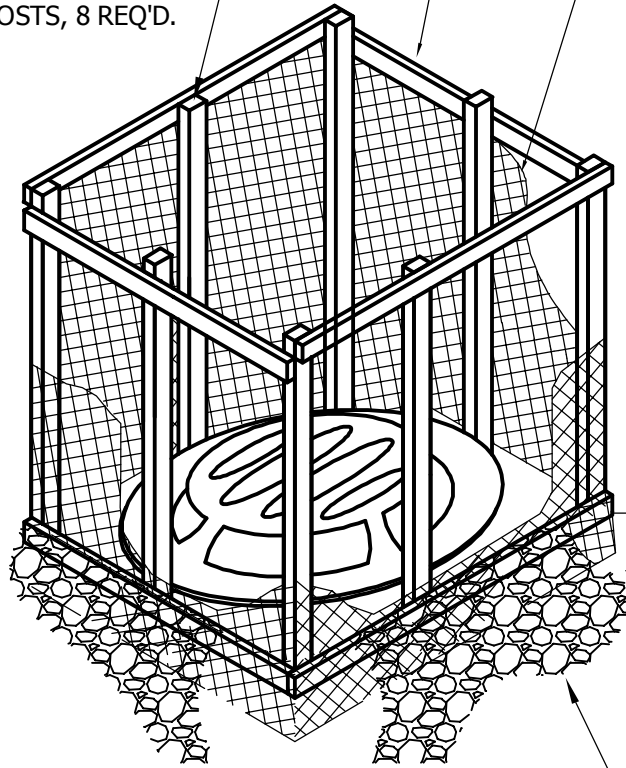

2'-6"

8-10" FABRIC FLAP- BURY UNDER ROCK TO PREVENT UNDERWASHING

8-10" FABRIC FLAP EXTENDING BEYOND BOTTOM 2"X4" - BURY UNDER ROCK TO PREVENT UNDERWASHING

1 1/2" WASHED ROCK  
1' DEEP X 1' WIDE

**NOTES:**

CONTRACTOR SHALL CONSTRUCT SILT BOX TO FIT AROUND THE INLET STRUCTURE WITH 6" MINIMUM CLEARANCE TO EDGES OF STRUCTURE. SILT BOX TO BE PLACED ON AN EVEN SURFACE 6" BELOW STRUCTURE OPENING. TOP OF SILT BOX TO EXTEND 18" MINIMUM ABOVE EXISTING GRADE.



**STANDARD DETAILS**

INLET PROTECTION  
SILT BOX FOR BEEHIVE CASTING

SPRING LAKE TOWNSHIP

Last Revision:

JAN 2010

Plate No.

ERO-4C

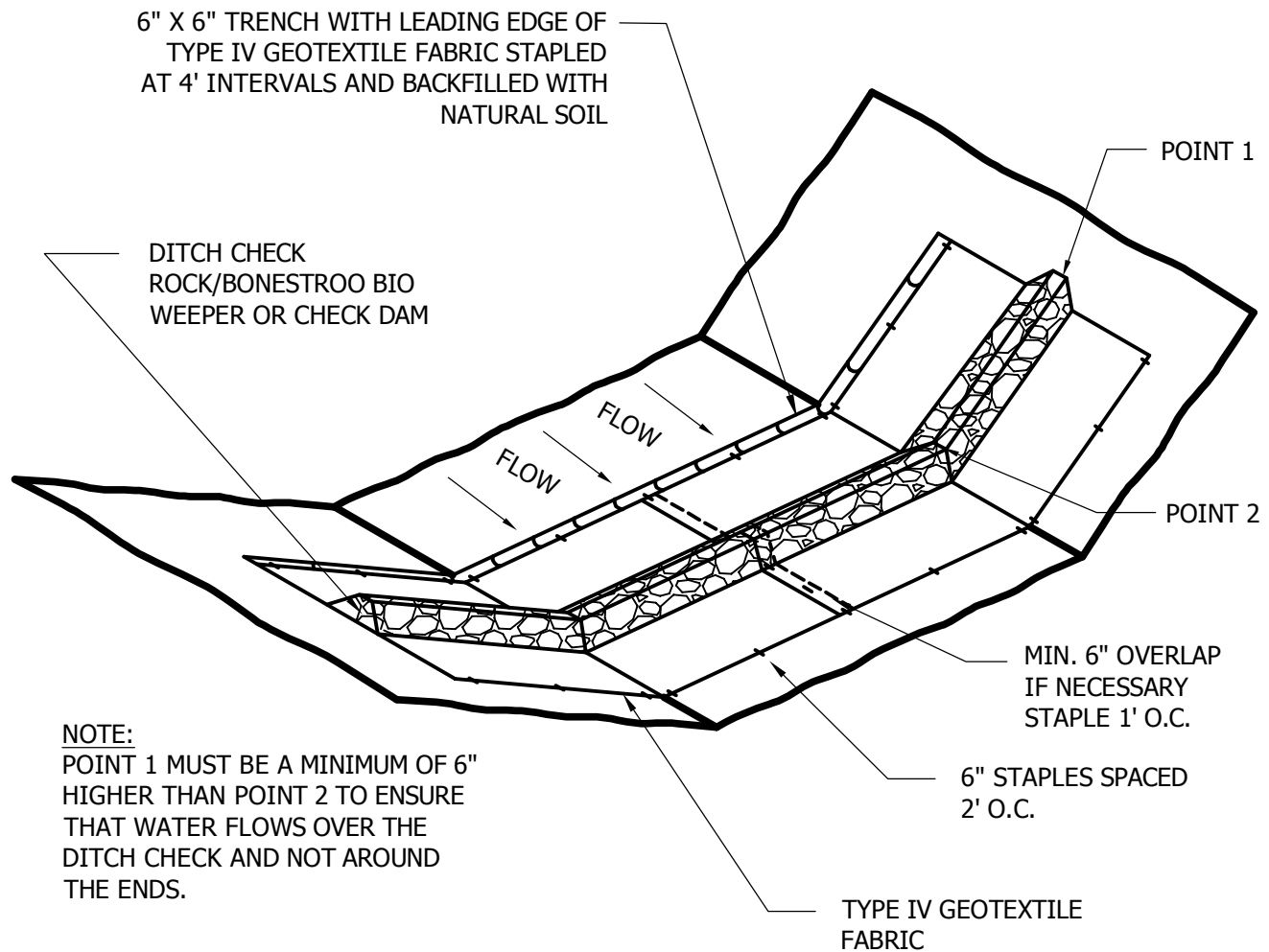

**NOTE:**  
 POINT 1 MUST BE A MINIMUM OF 6"  
 HIGHER THAN POINT 2 TO ENSURE  
 THAT WATER FLOWS OVER THE  
 DITCH CHECK AND NOT AROUND  
 THE ENDS.

**DITCH CHECK SPACING**  
 (USE FOR 5B, 5C, 5D, AND 5E)

DITCH GRADE (%)	INTERVAL (FT)
2	100
4	75
6	50
8	40
10	25
10+	25



**STANDARD DETAILS**  
 DITCH CHECK  
 3D VIEW FOR 5B, 5C SPACING

**SPRING LAKE TOWNSHIP**

Last Revision:  
 JAN 2010

Plate No.  
 ERO-5A

I. ROCK WEEPER

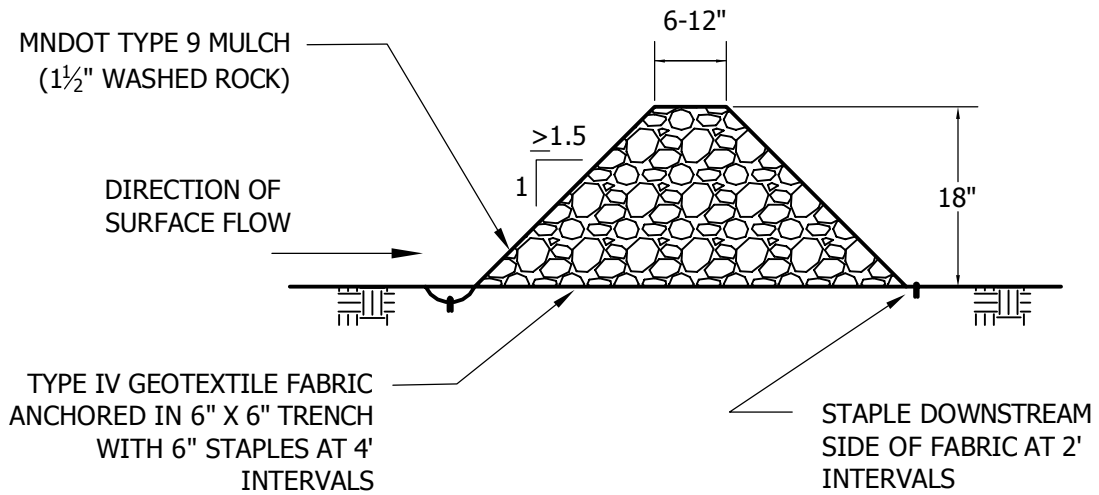

II. BONESTROO BIO WEEPER

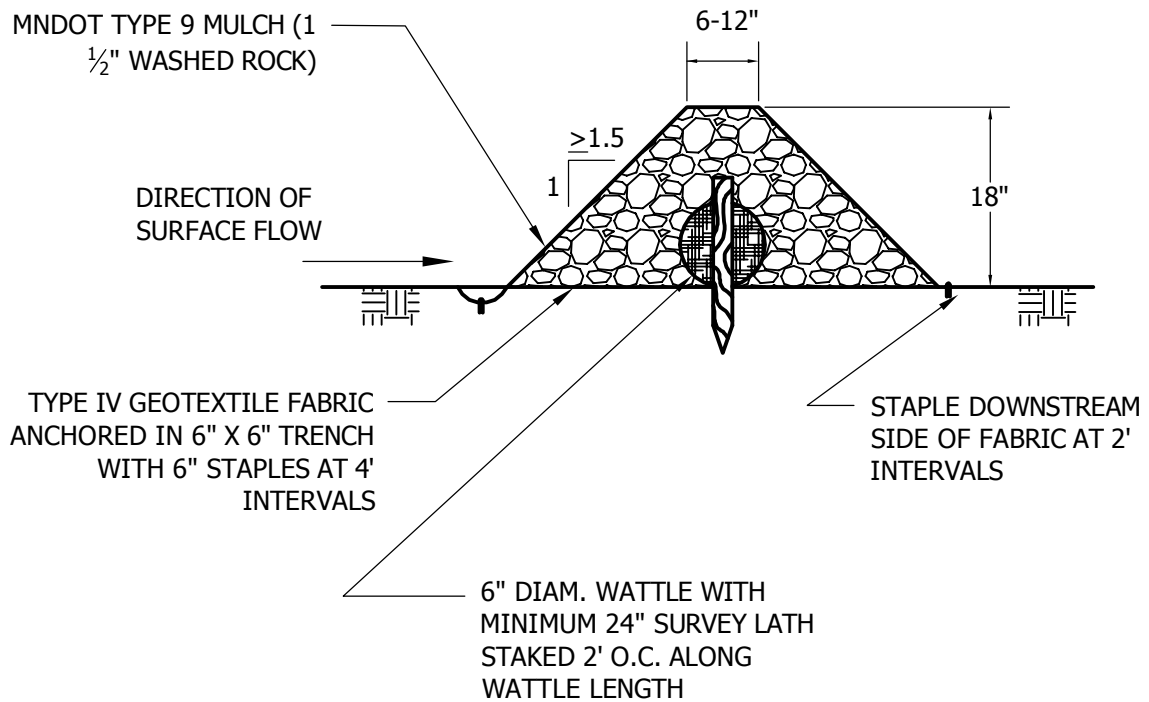

STANDARD DETAILS

DITCH CHECK  
ROCK WEEPER & BIO WEEPER

SPRING LAKE TOWNSHIP

Last Revision:

JAN 2010

Plate No.

ERO-5B

I. SMALL CHECK DAM

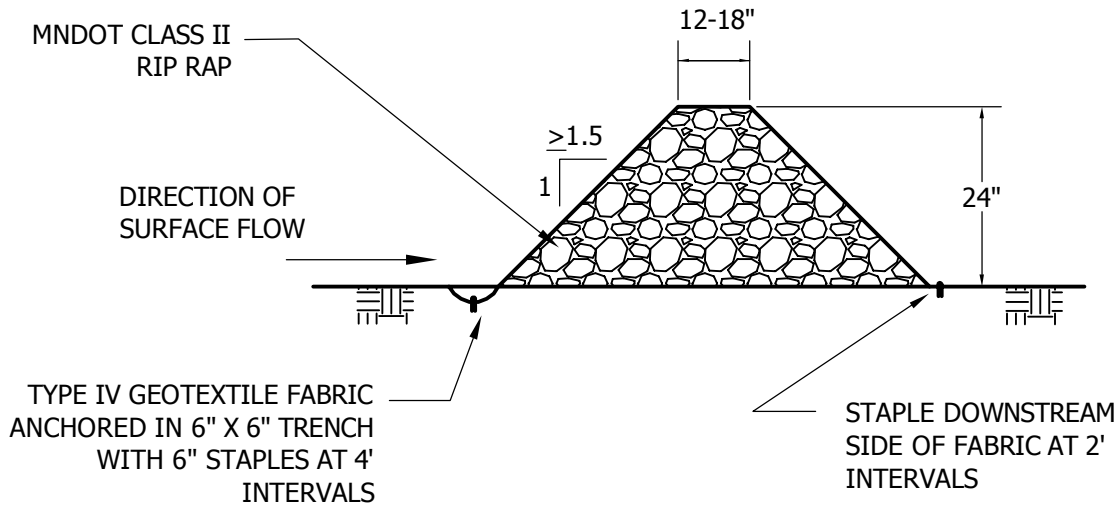

II. LARGE CHECK DAM

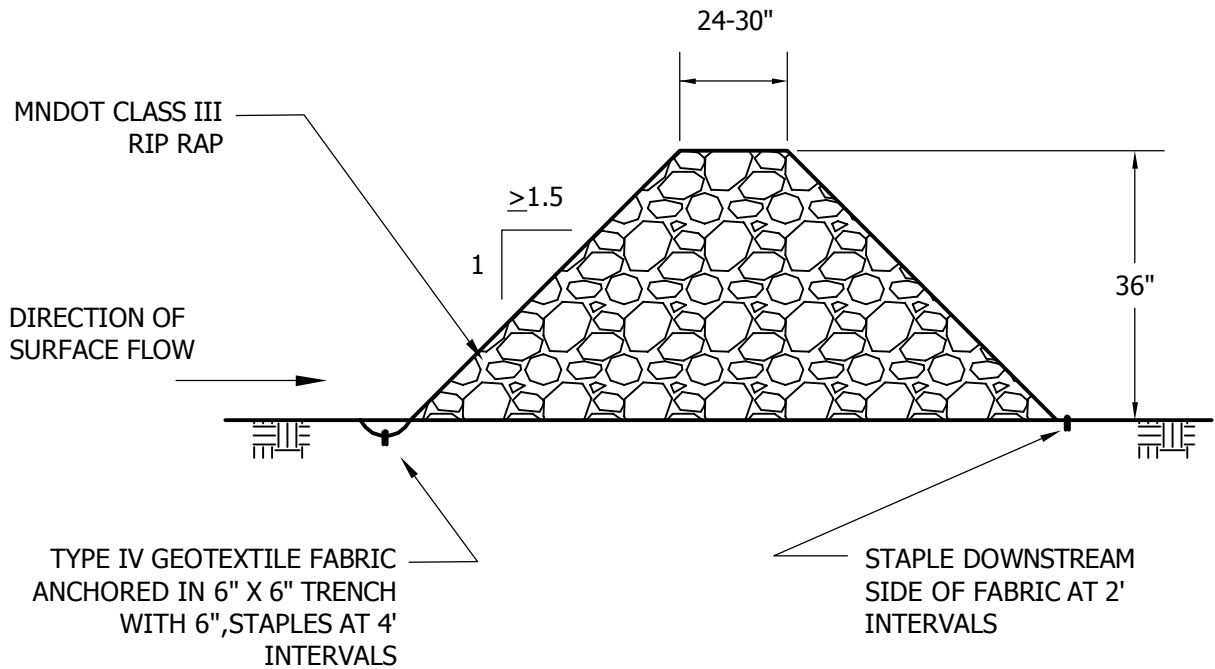

STANDARD DETAILS

DITCH CHECK  
SMALL AND LARGE CHECK DAM

SPRING LAKE TOWNSHIP

Last Revision:

JAN 2010

Plate No.

ERO-5C

NOTE:  
POINT 1 MUST BE A MINIMUM OF 6"  
HIGHER THAN POINT 2 TO ENSURE  
THAT WATER FLOWS OVER THE DIKE  
AND NOT AROUND THE ENDS.

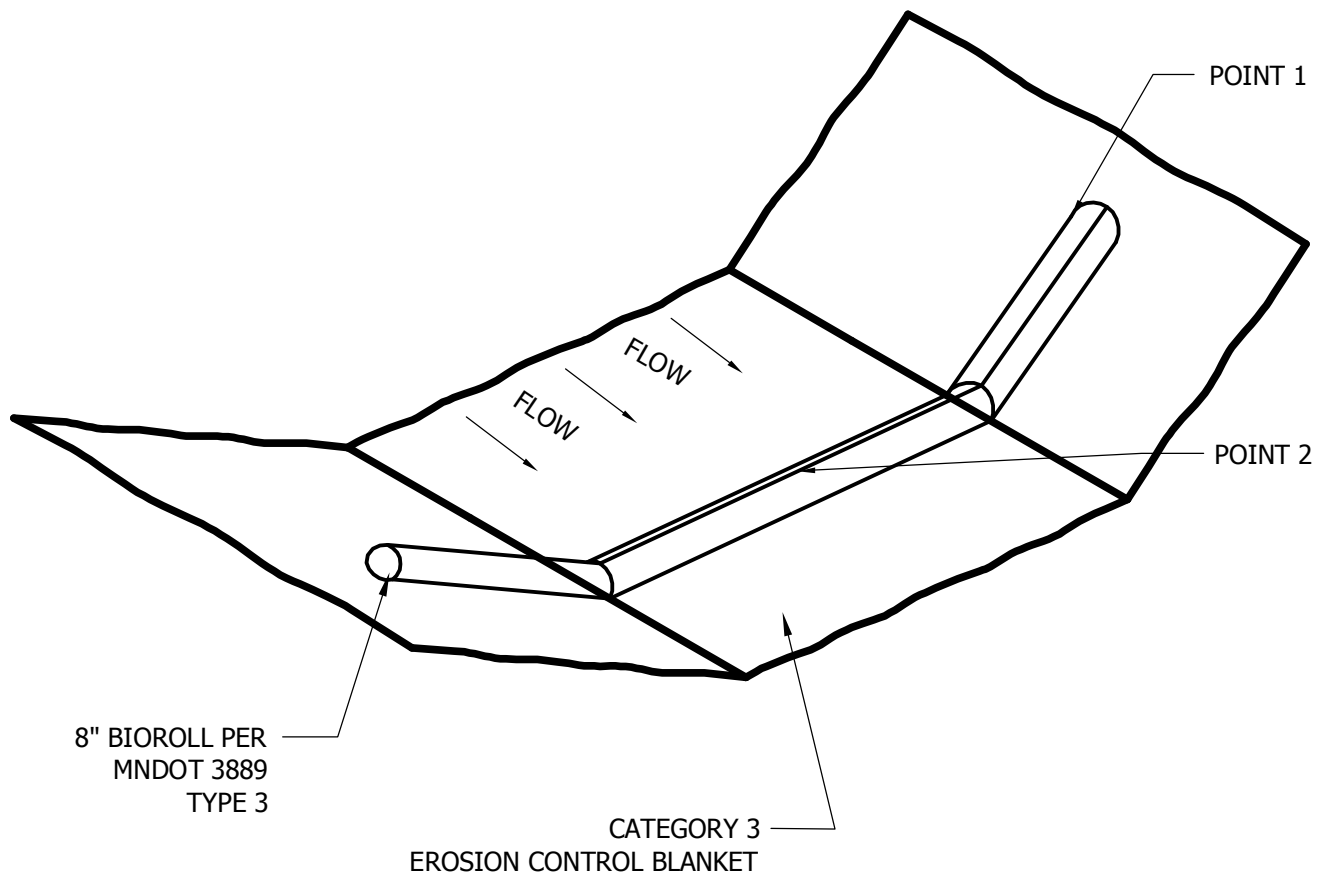

**STANDARD DETAILS**

DITCH CHECK  
BIOROLL SILT FENCE

SPRING LAKE TOWNSHIP

Last Revision:  
JAN 2010

Plate No.  
ERO-5D

NOTE:  
POINT 1 MUST BE A MINIMUM OF 6"  
HIGHER THAN POINT 2 TO ENSURE  
THAT WATER FLOWS OVER THE DIKE  
AND NOT AROUND THE ENDS.

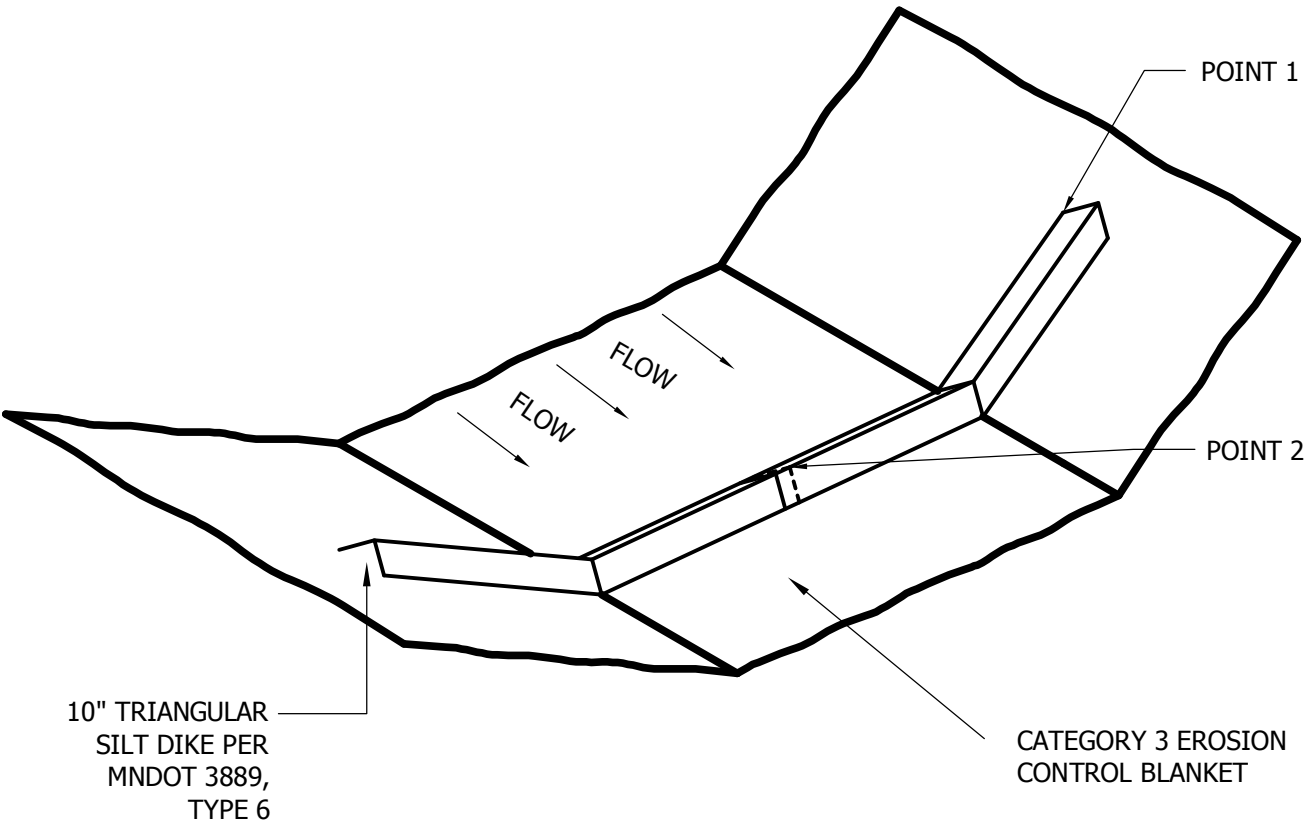

**STANDARD DETAILS**  
DITCH CHECK  
TRIANGULAR SILT DIKE

**SPRING LAKE TOWNSHIP**

Last Revision:  
JAN 2010

Plate No.  
ERO-5E



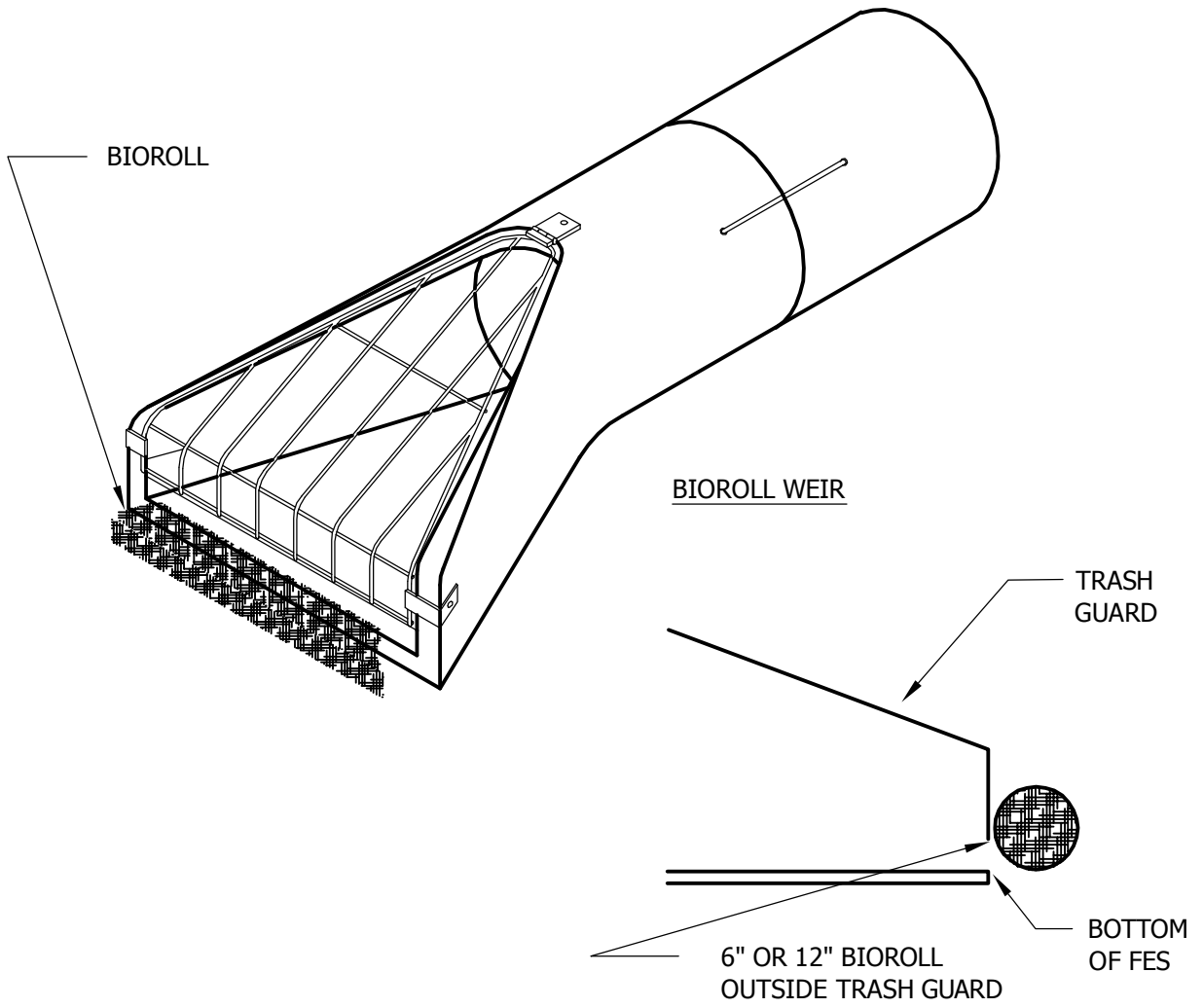

SILT FENCE AT FLARED END SECTION  
 TOP OF SILT FENCE TO BE LOWER THAN  
 LOWEST ADJACENT OVERFLOW

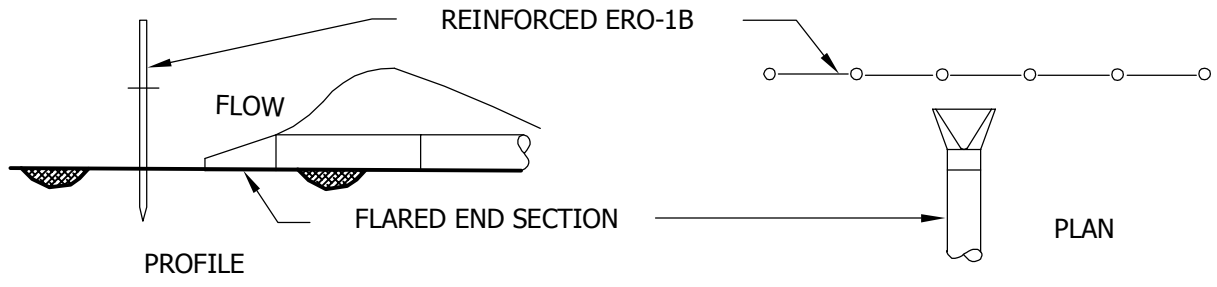

**STANDARD DETAILS**  
 FLARED END  
 EROSION CONTROL

**SPRING LAKE TOWNSHIP**

Last Revision:  
**JAN 2010**

Plate No.  
**ERO-6**

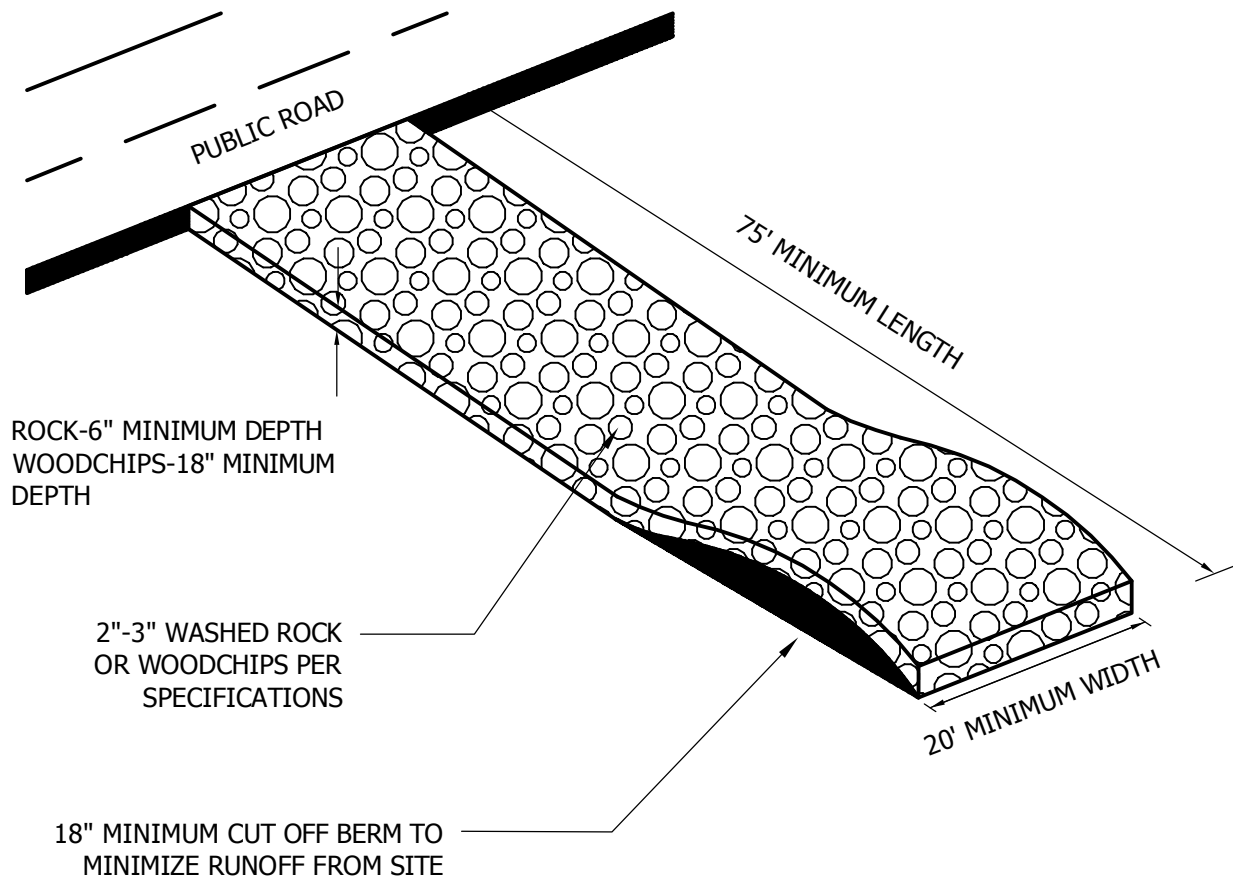

**NOTES:**

1. FILTER FABRIC SHALL BE PLACED UNDER ROCK TO STOP MUD MIGRATION THROUGH ROCK. FILTER FABRIC IS NOT REQUIRED UNDER WOODCHIPS.
2. 80% OF WOODCHIPS USED FOR CONSTRUCTION ENTRANCES MUST BE BETWEEN 2 INCHES AND 5 INCHES. NO CHIPPED-UP MANUFACTURED WOOD AND/OR CHEMICALLY TREATED WOOD IS ALLOWED.
3. ENTRANCE MUST BE MAINTAINED REGULARLY TO PREVENT SEDIMENTATION ON PUBLIC ROADWAYS. FUGITIVE ROCK OR WOODCHIPS WILL BE REMOVED FROM ADJACENT ROADWAYS DAILY OR MORE FREQUENTLY AS NECESSARY.



**STANDARD DETAILS**  
ROCK CONSTRUCTION ENTRANCE

**SPRING LAKE TOWNSHIP**

Last Revision:

JAN 2010

Plate No.

ERO-7

I. PLAN VIEW

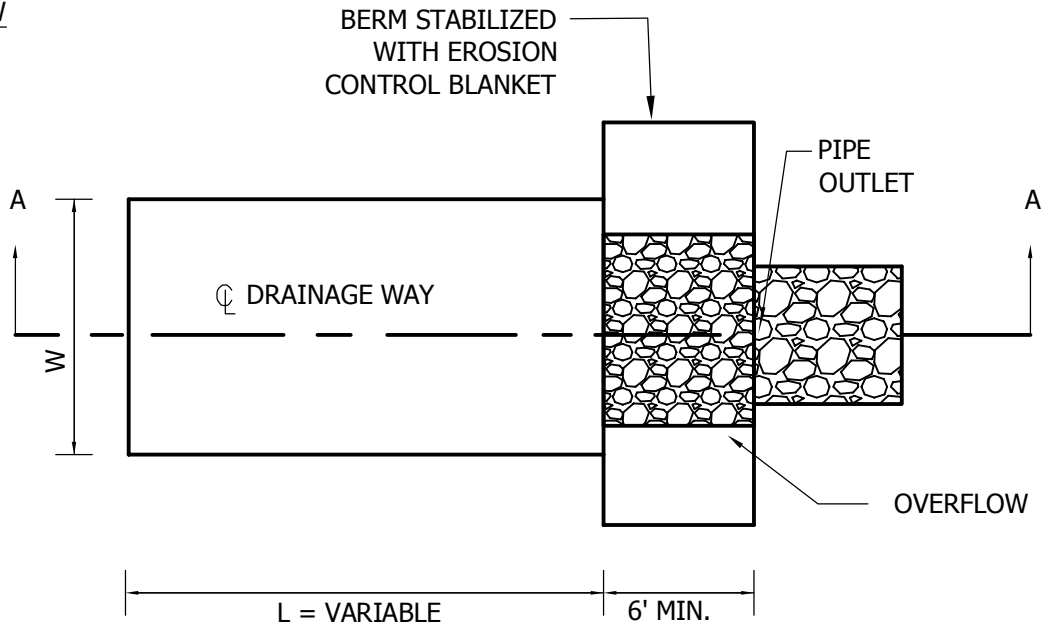

II. SECTION A-A

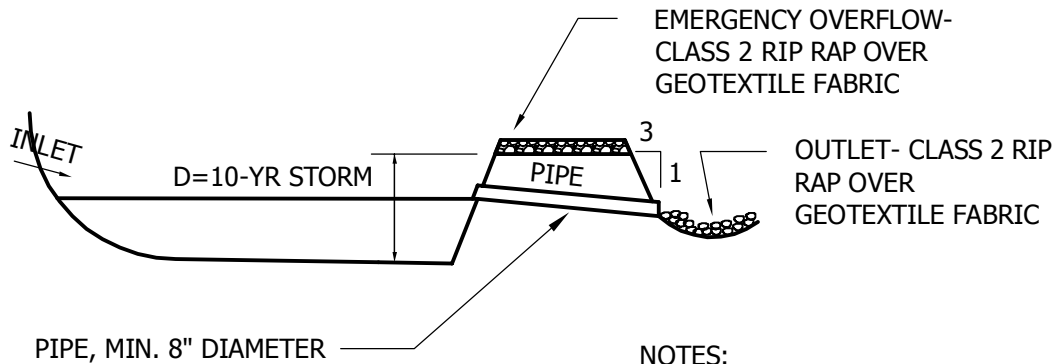

III. BASIN EMERGENCY OVERFLOW

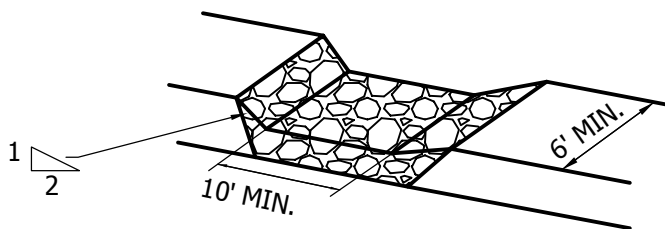

**NOTES:**  
 BASIN USED FOR 10 ACRES DRAINAGE AREA OR MORE. DESIGN RUNOFF VOLUME IS FROM A 2-YR, 24-HR STORM PER ACRE DRAINED TO THE BASIN. BASIN VOLUME MUST BE A MIN. OF 1800 CUBIC FEET/ACRE. SEE PLANS/SPECIFICATIONS FOR BASIN DIMENSIONS AND PIPE SIZE AND SLOPE.



**STANDARD DETAILS**  
 TEMPORARY SEDIMENT BASIN  
 PIPE OUTLET

**SPRING LAKE TOWNSHIP**

Last Revision:

JAN 2010

Plate No.

ERO-8A

**I. PLAN VIEW**

**NOTES:**

BASIN USED FOR 10 ACRES DRAINAGE AREA OR MORE. DESIGN RUNOFF VOLUME IS FROM A 2-YR, 24-HR STORM PER ACRE DRAINED TO THE BASIN. BASIN VOLUME MUST BE A MIN. OF 1800 CUBIC FEET/ACRE. SEE PLANS/SPECIFICATIONS FOR BASIN DIMENSIONS AND PIPE SIZE AND SLOPE.

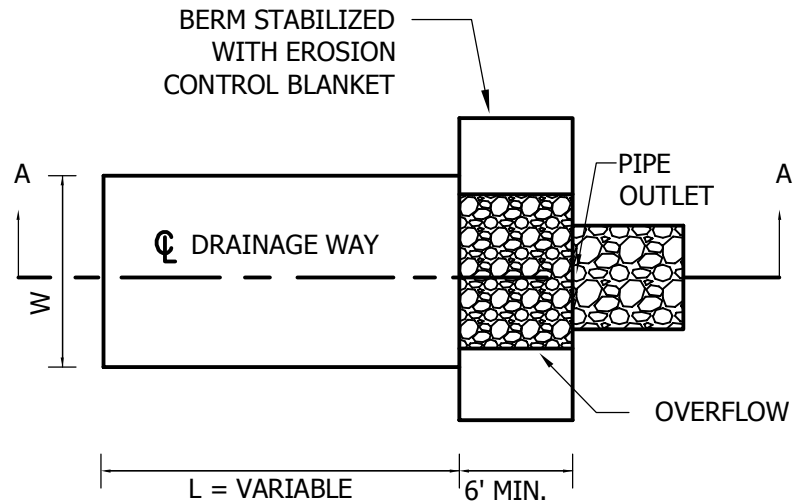

**II. SECTION A-A**

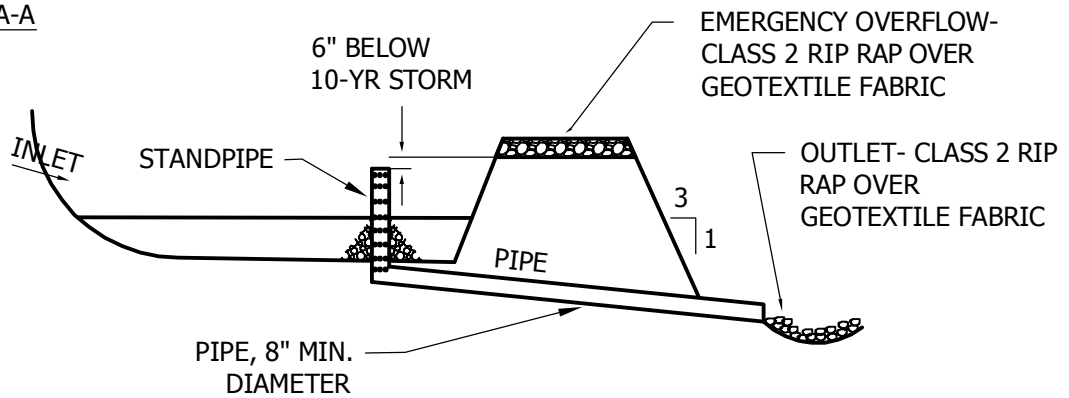

**III. BASIN STANDPIPE AND EMERGENCY OVERFLOW**

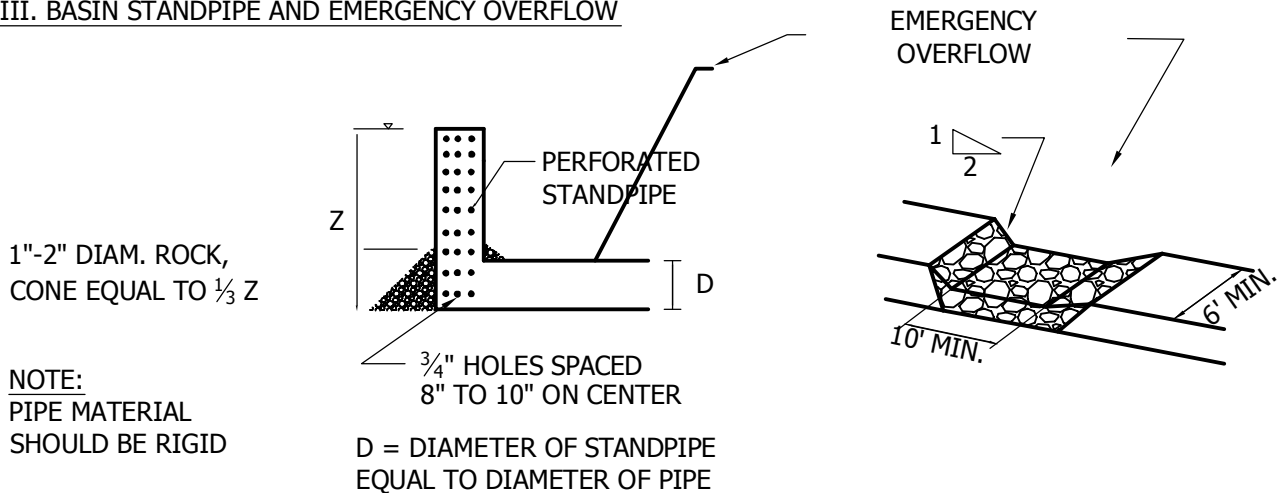

1"-2" DIAM. ROCK, CONE EQUAL TO 1/3 Z

NOTE:  
PIPE MATERIAL SHOULD BE RIGID

D = DIAMETER OF STANDPIPE EQUAL TO DIAMETER OF PIPE



**STANDARD DETAILS**  
TEMPORARY SEDIMENTATION BASIN  
STANDPIPE OUTLET

**SPRING LAKE TOWNSHIP**

Last Revision:

JAN 2010

Plate No.

ERO-8B

I. PLAN VIEW

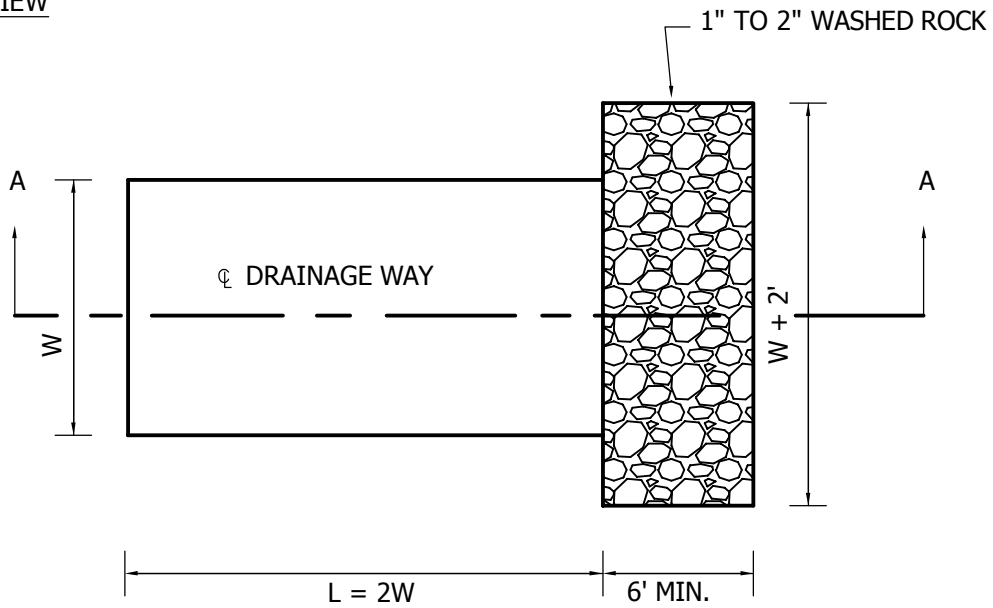

II. SECTION A-A

DIRECTION OF SURFACE FLOW

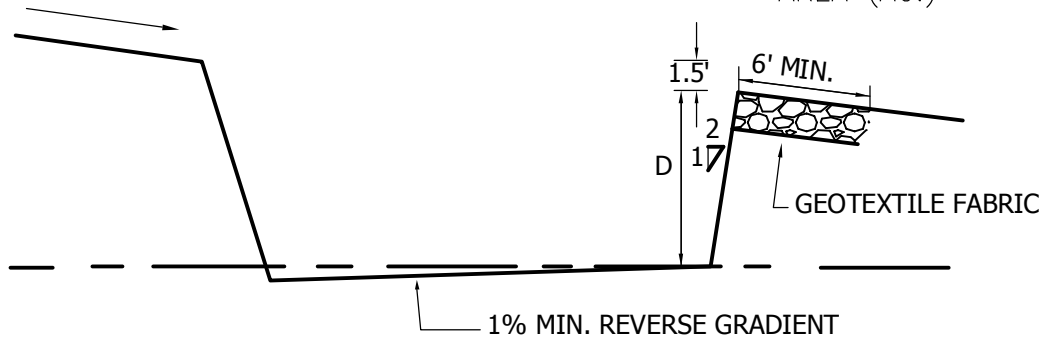

NOTE:

D=3' MIN, 5' MAX  
 W=10' MIN, 25' MAX  
 W(FT.)= 10 X DRAINAGE AREA (AC.)

III. TRAP OUTLET

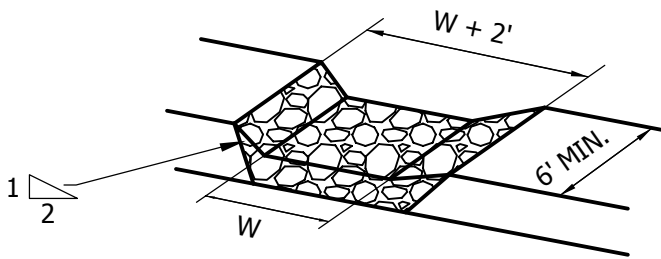

NOTES:

TRAP USED FOR 2.5 ACRES DRAINAGE AREA OR LESS. DESIGN VOLUME IS A MINIMUM OF 1800 CUBIC FEET PER ACRE OF CONTRIBUTING DRAINAGE AREA.



**STANDARD DETAILS**  
 TEMPORARY SEDIMENT TRAP

**SPRING LAKE TOWNSHIP**

Last Revision:

JAN 2010

Plate No.

ERO-9

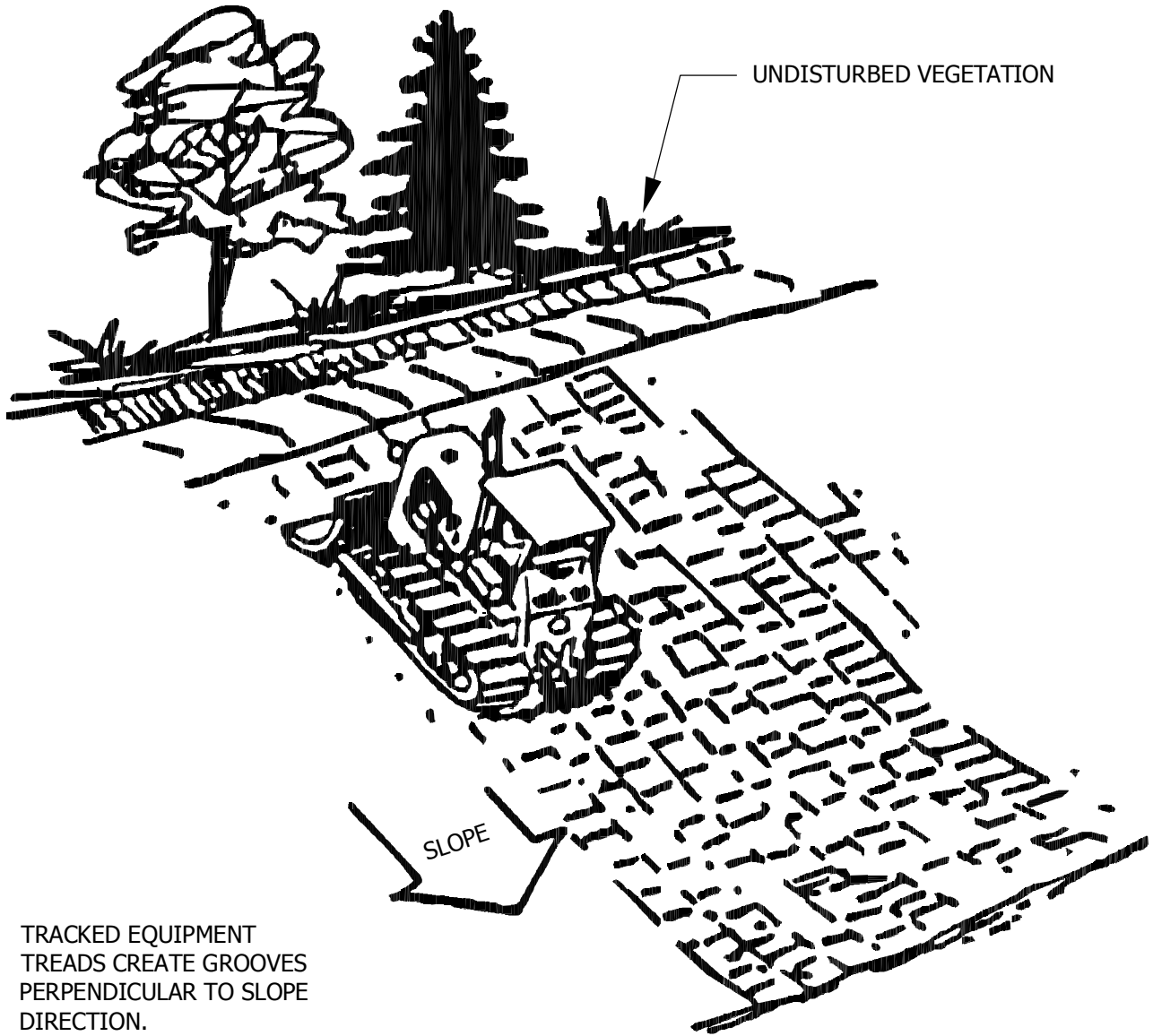

TRACKED EQUIPMENT  
TREADS CREATE GROOVES  
PERPENDICULAR TO SLOPE  
DIRECTION.

**NOTE:**  
ALL SLOPES WITH A GRADE EQUAL TO OR STEEPER THAN 3:1  
REQUIRE SLOPE TRACKING. SLOPES WITH A GRADE MORE GRADUAL  
THAN 3:1 REQUIRE SLOPE TRACKING IF THE STABILIZATION METHOD  
IS EROSION CONTROL BLANKET OR HYDROMULCH.



**STANDARD DETAILS**  
SLOPE TRACKING

SPRING LAKE TOWNSHIP

Last Revision:

JAN 2010

Plate No.

ERO-10